

## SUMMARY

|   | Pages |
|---|-------|
| <b>Operators safety precautions</b> .....         | 5     |
| <b>SECTION I Specifications</b> .....             | 6     |
| <b>SECTION II Attachment to the tractor</b> ..... | 8     |
| <b>SECTION III Operation</b> .....                | 12    |
| <b>SECTION IV Adjustment</b> .....                | 25    |
| <b>SECTION V Twine Knotter Adjustments</b> .....  | 35    |
| <b>SECTION VI Safety devices</b> .....            | 58    |
| <b>SECTION VII Maintenance</b> .....              | 66    |
| <b>SECTION VIII Accessories</b> .....             | 72    |
| <b>Operator Parts List</b> .....                  | 75    |

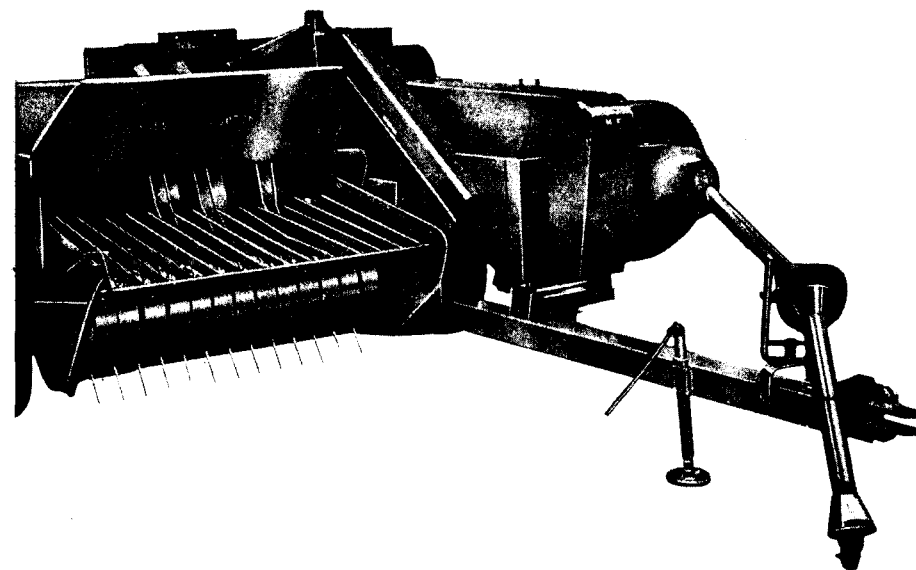

Fig. 1

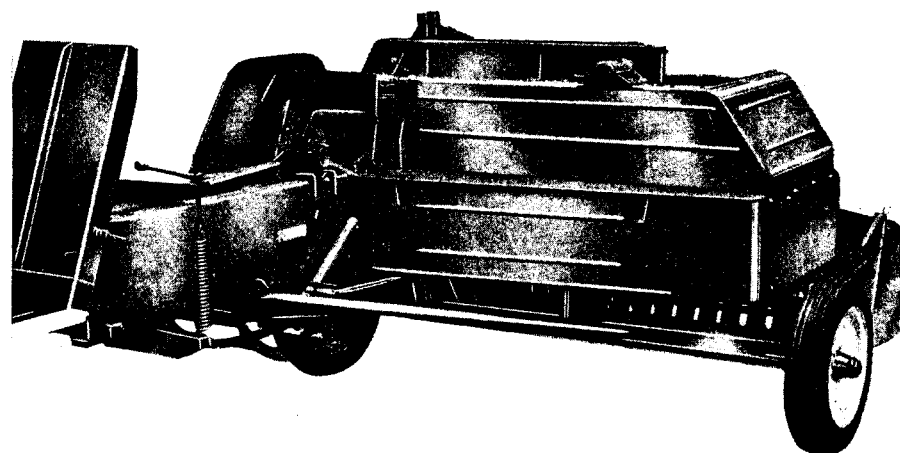

Fig. 2

Fig. 1 - FRONT VIEW - N° 20 BALER

Fig. 2 - REAR VIEW - N° 20 BALER

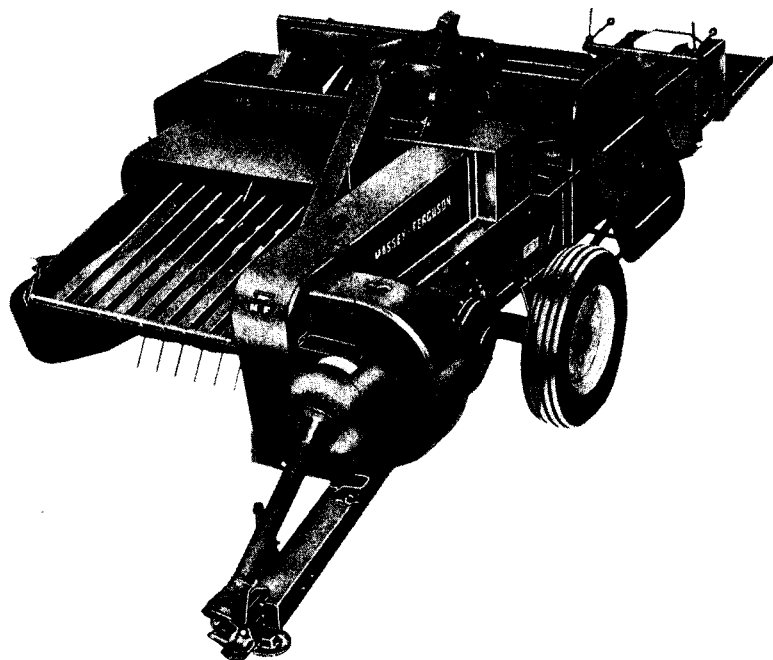

Fig. 3

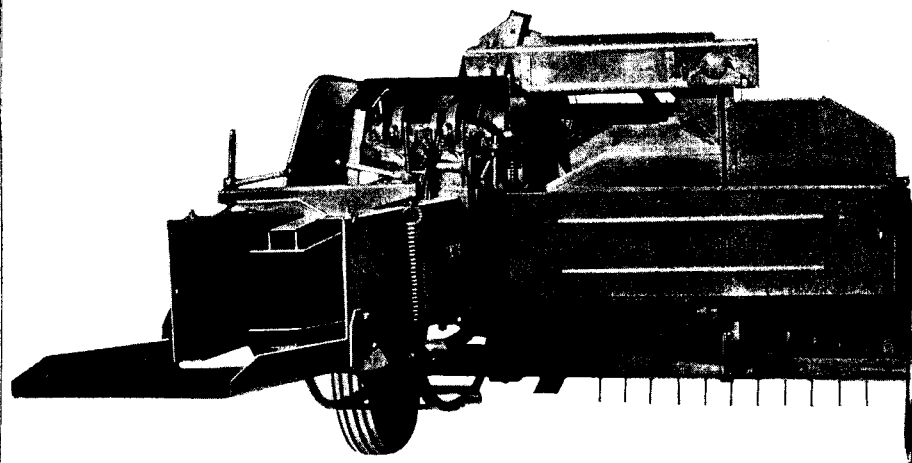

Fig. 4

## Operators Safety Precautions

Accidents still occur when using balers - some of them fatal. The M-F 15 and 20 balers incorporate more safety features than required by U.K. or continental regulations and the avoidance of accidents depends primarily on the operator.

ALWAYS disengage the P.T.O. drive, stop the tractor engine, allow the packers to reach bottom dead centre, and apply the tractor wheel brakes before working on the baler.

ALWAYS observe the above procedure when threading the needles.

ALWAYS replace any guards if these have been removed for any reason.

ALWAYS keep well clear of the pickup.

ALWAYS keep hands clear of the knotter and needle gate when the baler is attached to the tractor and the tractor engine is running.

ALWAYS ensure that the P.T.O. guards are fitted and in good working condition.

ALWAYS use a tractor big enough when using the baler on steep slopes.

ALWAYS keep children away from machines when they are operating.

ALWAYS take care not to trap hands between the flywheel and flywheel cover when turning the machine by hand.

ALWAYS BE CAREFUL. Even after observing these requirements accidents can still happen.

Fig. 3 - FRONT VIEW - No 15 BALER

Fig. 4 - REAR VIEW - No 15 BALER

SECTION I

**SPECIFICATIONS**

**DIMENSIONS**

|   | <b>Baler</b>                   |                                |
|---|--------------------------------|--------------------------------|
|   | <b>15</b>                      | <b>20</b>                      |
| Overall length .....  | 15'                            | 17' 8"                         |
| Overall width .....   | 7' 9 1/2"                      | 8' 5 1/2"                      |
| Overall height (packers down) .....   | 5' 3 3/4"                      | 5' 3 3/4"                      |
| Weight .....  | 2,920 lbs                      | 3,090 lbs                      |
| Pick up width .....   | 48 in                          | 56 in                          |
| Pick up width (including gathering shields)   | 56 in                          | 64 in                          |
| Plunger fitted with<br>(n° 15 baler up to serial n° 7500) .<br>(n° 20 baler up to serial n° 68000)<br>(From those serial n° ) |                                | Pads<br>6 Rollers<br>3 Rollers |
| Bale chamber size .....   | 18 in x 14 in                  |                                |
| Plunger stroke .....  | 28 in                          |                                |
| Plunger speed .....   | 80 to 90 strokes<br>per minute |                                |

**Tying**

- Bale length ..... Twine knotter 2 Tie  
Adjustable 20 in to 50 in
- Bale end dimen-  
sions ..... 18 in x 14 in
- Twine runnage ... 230 ft/lb (150 m/kg) to 340 ft/lb (220  
m/kg) for high density and low density  
bales respectively

NOTE : "In this Instruction Book left-hand side (L.H.S.) and right-hand side (R.H.S.) are referred to when facing in the direction of travel of the machine. i.e. the operator looking forward from the rear of the machine".

**Main drive gear box**

- Oil capacity (to level plug) ..... 10 pints
- Type..... SAE 90 EP hypoid
- P.T.O. shaft recommended speed ..... 540 r.p.m. to 610 r.p.m.
- Baler driving shaft :
- On 15 baler ..... Single shaft
- On 20 baler ..... Double shaft

**Tyres**

|   |       | <b>Size</b> | <b>Pressure</b> |
|---|-------|-------------|-----------------|
| — L.H. Wheel standard ..  | 6 ply | 6-50 - 16   | 40 lbs/sq in    |
| — L.H. Wheel N° 20 baler<br>(Wire twister) and<br>optional (N° 20 baler<br>only)..... | 6 ply | 9-00 - 16   | 40 lbs/sq in    |
| — R.H. Wheel .....  | 4 ply | 5-00 - 16   | 28,4 lbs/sq in  |

SECTION II

## ATTACHMENT TO THE TRACTOR

P.T.O. driven model 15 and 20 balers may be attached to all types of tractor, the horse-power of which is 30 or above. However, in very hilly or soft ground conditions, or where heavy sledges or wagons are used, a 35 - 50 horsepower tractor is to be preferred.

The model 15 and 20 balers are available with a suitable drawbar and suitable P.T.O. drive shaft arrangements to enable them to be fitted to practically all models of tractor on the market. Whilst these balers can be used quite satisfactorily on tractors fitted with fixed lateral drawbars a swinging type drawbar is to be preferred as it generally allows better cornering.

The baler hitch plate can be adjusted vertically to allow the baler drawbars to be approximately level when fitted to the tractor. The baler drawbar can be quickly changed from the working to the transport position by the release of a spring loaded plunger (operated by means of a rope from the tractor seat in the case of the model 20 baler - refer. to fig. 5).

### 15 AND 20 BALER P.T.O. CONNECTION

Because the distance from the end of the tractor P.T.O. shaft to the hitchpin varies on different makes and models of tractor, optional lengths of P.T.O. shaft are available for both 15 and 20 model balers.

On the majority of European manufactured tractors the P.T.O. shaft/hitchpin distance varies from 17" - 23", whilst on most tractors produced in North America or adhering to A.S.A.E. standards, this distance is 14". The M-F tractor swinging drawbar is adjustable to 14" or 19" distances.

- Fig. 6
- |  |                                     |
|--|-------------------------------------|
| A - ALTERNATIVE HOLES FOR WOODEN FINGERS | E - STOP BOLT                       |
| B - LOCKING PLATE                        | F - TENSIONER SPROCKETS             |
| C - PACKER CHAIN DRIVE                   | G - PICK UP AND KNOTTER DRIVE CHAIN |
| D - SUPPORT STRAP                        | H - TRANSPORT NOTCH                 |

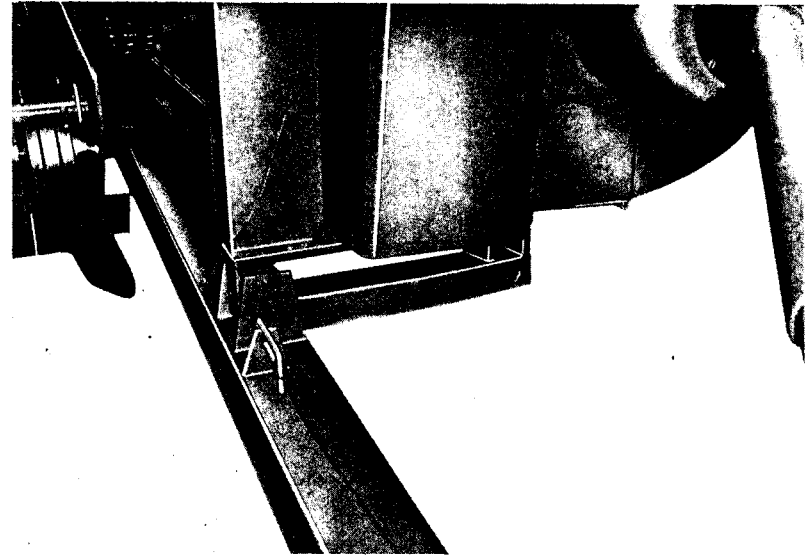

Fig. 5

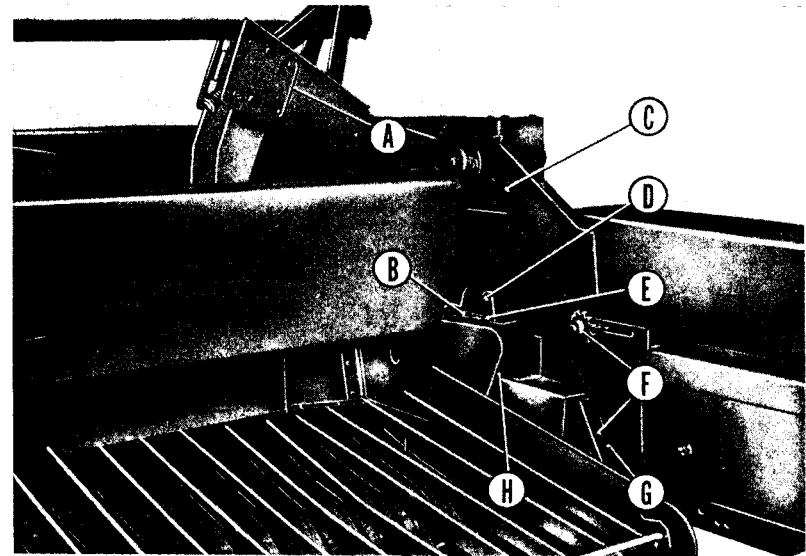

Fig. 6

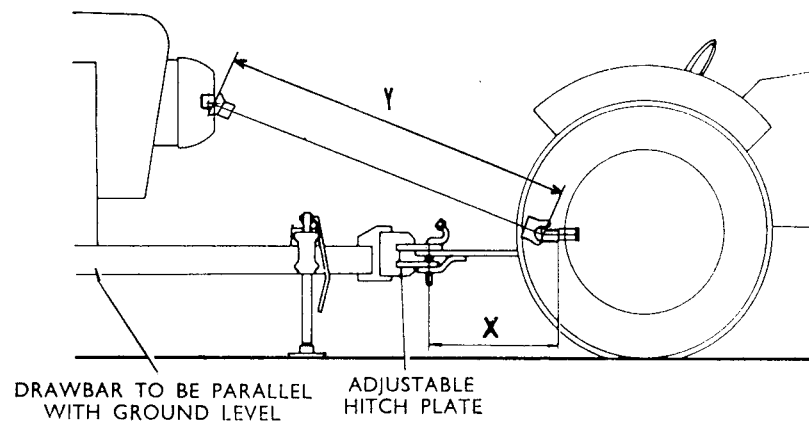

Fig. 7

P.T.O. shafts for 15 and 20 Balers are supplied in three optional lengths to suit tractors, the distance of which between P.T.O. shaft and hitch point is

- From 14" to 17" = short shaft
- From 17" to 23" = long shaft
- From 23" to 26" = extra long shaft

### 15 BALER P.T.O. CONNECTION

The model 15 baler is fitted with single telescopic shaft.

|                  | Distance "Y" between joint crosses |         |
|------------------|------------------------------------|---------|
|                  | Maximum                            | Minimum |
| Short shaft      | 40"                                | 26"     |
| Long shaft       | 48"                                | 30"     |
| Extra long shaft | 57"                                | 35"     |

**IMPORTANT :** The distance "Y" must always be comprised within the above minimum and maximum figures to avoid shaft interference or insufficient coupling length (5" minimum).

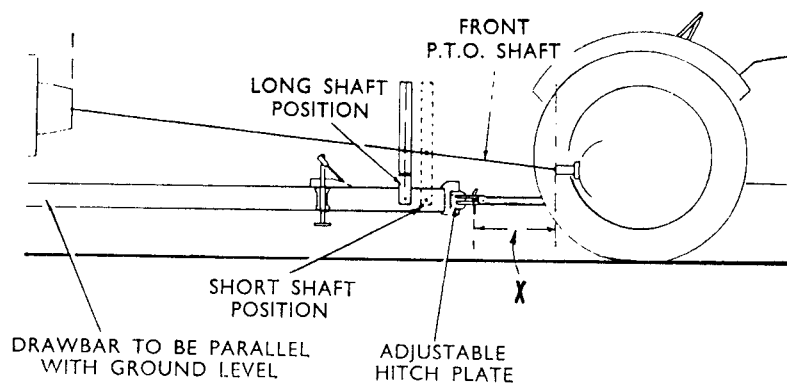

Fig. 8

### 20 BALER P.T.O. CONNECTION

The model 20 baler is supplied with a double shaft drive. The rear telescopic shaft being the same length on all machines. The maximum length is 51" whereas the minimum length is 30".

**IMPORTANT :** Shaft length must always be comprised within these figures.

The front fixed shaft is supplied on three optional lengths.

- Short shaft - from 18 to 18 1/2 \*
- Long shaft - from 26" to 27" \*
- Extra long shaft - 31"

\* according to the manufacturer's one.

The P.T.O. shaft support bracket is supported in the drawbar rear holes, in the case of short shafts.

Viewed from the side the two shafts should be kept in line as far as possible, the centre bearings being positioned vertically to achieve this objective by the use of the correct alternative holes provided in the support bracket.

Fig. 7 - 15 BALER P.T.O. CONNECTION

Fig. 8 - 20 BALER P.T.O. CONNECTION

## SECTION III

**OPERATION**

The crop must be so arranged that windrows are regular and have the same section to assure even feeding and smooth running of the baler.

**It is recommended to make small windrows and to drive quickly.**

Check that windrow height is lower than crop guide bar height, thus avoiding the possibility of baler over loading by picking up too large windrows.

Windrowing should be operated in the same direction as mowing.

This permits the placing of leaves in the middle of the windrow and assures even drying and reduces colour loss to a minimum.

It is important to turn over hay completely to avoid irregular drying.

**TWINE**

The twine normally used for medium and relatively heavy bales should have a runnage of 230 ft/lb. (150 m/kg.) known as No. 2. Twine having a runnage of up to 340 ft/lb. (220 m/kg.) known as No. 1 can be used for very light bales and it is permissible, but not recommended, that twine having a runnage of 185 ft/lb. (120 m/kg.) known as 2 A may be used for really heavy bales. Under the latter circumstances a single bowed knot can be expected and knotter adjustment may become more critical.

Prior to use balls of twine should be stored on end in a dry atmosphere, otherwise distortion of the spool and consequent snarling of the twine may cause trouble in the field.

Four spools of twine are carried on the machine, the two left-hand spools being for the left-hand knotter, and the two right-hand spools being for the right-hand knotter. Four spools of twine having a runnage of 230 ft/lb. are sufficient for almost 1000 bales of average length.

## OPERATION

The ends of the twine from the spools should be threaded as shown in illustrations No. 9 and 10.

From the twine box, both twines should pass under the twine tensioner plate (Ref. A) and downwards through the porcelain guide (Ref. B) to the needle gate guide (Ref. C), through the guide D then one each through one of the left and right hand guides fitted to the underside of the needle guard E and thence through the eyes of the needles.

Then attach ends to cross plate of the needle guard.

Trip knotter mechanism and slowly rotate flywheel in the arrowed direction to place the twine in the twine discs.

Baler is now ready to operate.

Knots obtained during working may be tied as shown in A or B fig. 11.

In (A) both loose ends are pulled through and should be cut off cleanly and squarely.

In (B) only one end is pulled through and this is also correct.

If the bow is pulled out by hand, the two ends should be the same length and cut off cleanly and squarely.

## TWINE TENSION PLATE ADJUSTMENT

To ensure even and proper tying of bales the twine is held under slight tension by means of the twine tension plate which, after the paint was rubbed off, should result in a drag of some 4 lbs. maximum (2 kg) See item A, fig. 9.

Fig. 9 - 10 - THREADING THE TWINE

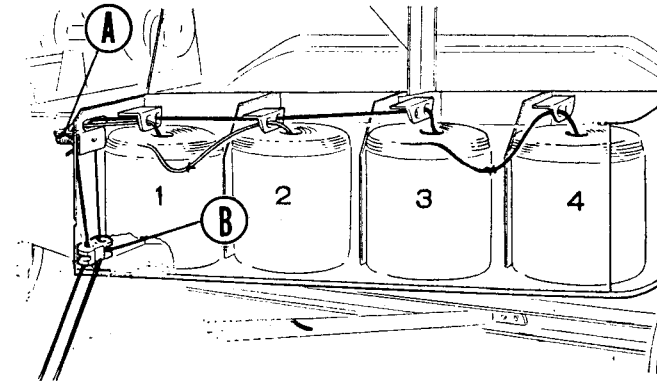

Fig. 9

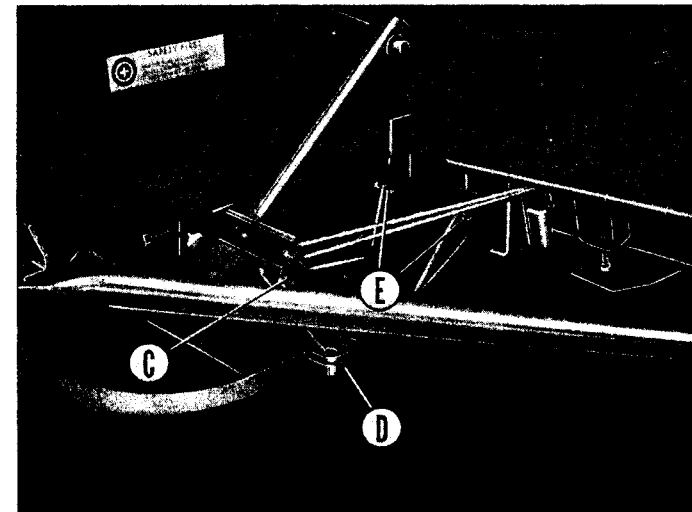

Fig. 10

### CHECKING FOR CORRECT OPERATION

Before beginning to work it is recommended to turn baler by hand.

This precaution avoids any risk of damage when the baler is P.T.O. operated if any adjustment or timing were out of order.

Proceed as follows:

- Engage knotter mechanism by rotating metering wheel.
- Rotate flywheel by hand in the arrowed direction.

Continue to turn flywheel until the knotter and needle mechanism have completed one complete cycle and are disengaged by the knotter clutch.

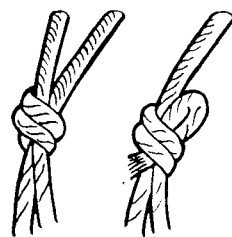

A B  
Fig. 11

### PICKING UP THE CROP

- 1) It is a common fault to lower the pickup too low resulting in soil (sometimes of an abrasive nature) being thrown into the crop. This results in excessive plunger wear. The pickup height should normally be such that the distance between the tip of the tine and the surface of the ground is between 1" and 2". The pickup height may be adjusted by using the proper hole for the stop bolt in the support strap (see fig. 6, item "E").
- 2) The crop guide should be so positioned that the tines are 1" - 2" above the tips of the pickup tines. (See "z", fig. 19). The crop guide partially compresses the crop in conjunction with the pickup tines and may be adjusted to suit different crops. A very long dry brittle crop may require more spring tension than damp short crops.
- 3) A steady flow of material into the baler goes a long way to ensuring well-packed bales of even density. A well-made swath will obviously help the operator.

### TRACTION SPEED

Wherever possible and whatever gear is selected it is preferable to use a P.T.O. speed of 610 R.P.M. which corresponds to a baler speed of 90 plunger strokes per minute. 80 strokes per minute on the baler at a P.T.O. speed of 540 R.P.M. is satisfactory but correspondingly slower.



## OPERATION

### BALE LENGTH ADJUSTMENT

Bale length can be adjusted from 20" to 50" by loosening the two securing nuts of the stop ref. A and by rotating this stop.

This stop may be positioned in one of the two holes of the lever.

This permits an increased adjustment range.

A nominal bale length of 38" - which is double the breadth - allows bales to be stacked securely.

### BALE SHAPE ADJUSTMENT

Good bale shape depends on three factors:

- 1) Even feeding of the crop into the machine.
- 2) The correct adjustment of the machine and correct speed of operation.
- 3) Correct shearblade adjustment and sharpness of the shearblades.

The following adjustments can be made:

The wooden packer forks can be positioned in alternative holes, as shown at "A", fig. 6. The packers are normally located in the centre holes.

The packers may also have their rake adjusted by sliding the adjusting block, item "A" fig. 14, to the right or left.

If the bales are too tight on the left-hand side, i.e. over-packed, as shown in the fig. 13 A, then the sliding block, item "A" fig. 14, should be moved to the left after loosening the two securing bolts. In extreme conditions the wooden packer forks should be repositioned in the right-hand side holes to reduce the amount of packing.

On the other hand should the bales be too tight on the right-hand side (i.e. adjacent to the shearknives) as shown in fig. 13 B, then the sliding block should be positioned to the extreme right, or, in extreme conditions, the wooden packer forks should be positioned in the extreme left-hand side.

Fig. 12 - BALE LENGTH ADJUSTMENT  
Fig. 14 - A - PACKER ADJUSTER B - BOX

Fig. 12

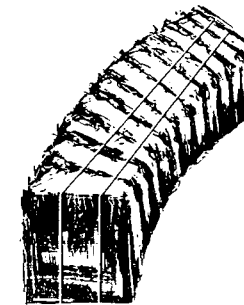
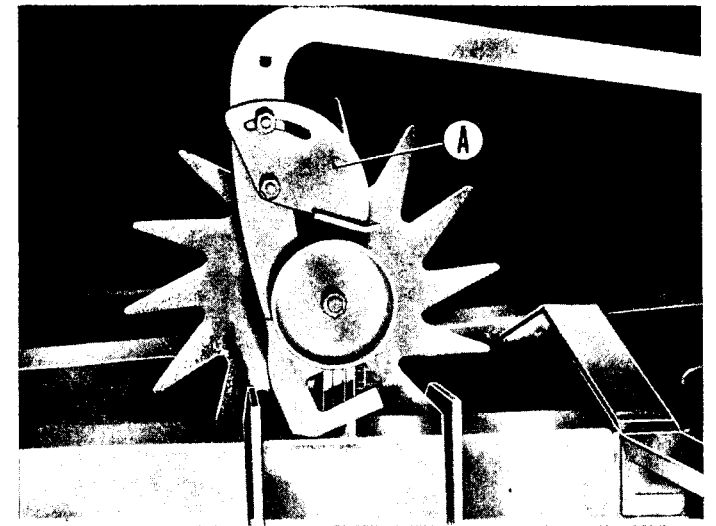

Fig. 13 A

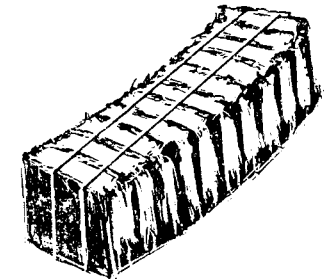
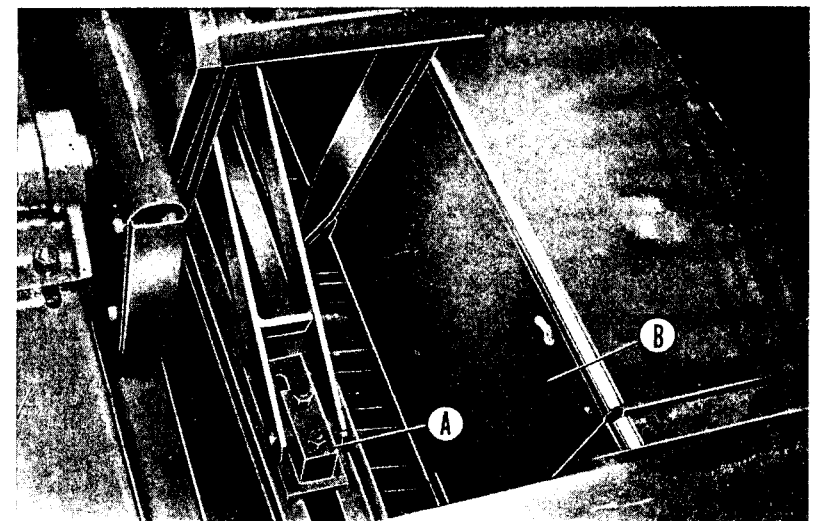

Fig. 13 B

Fig. 14



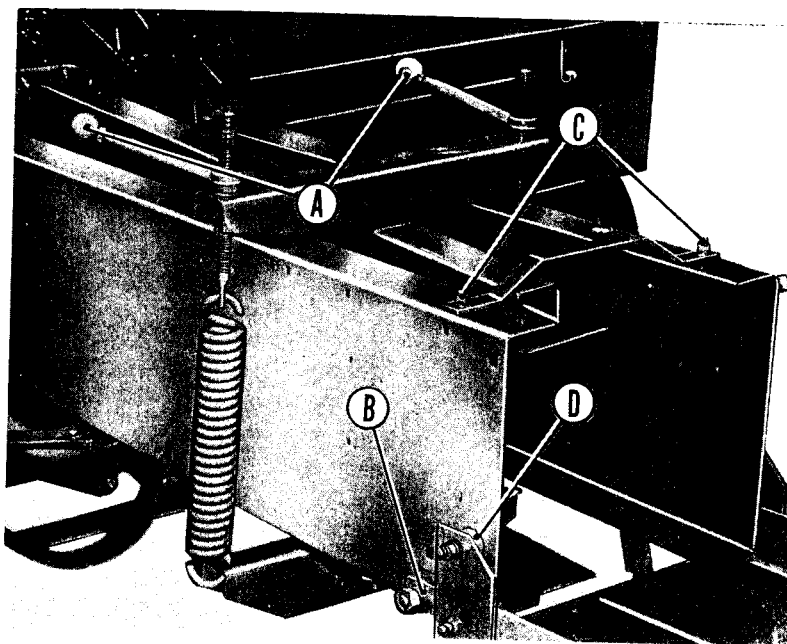

Fig. 15

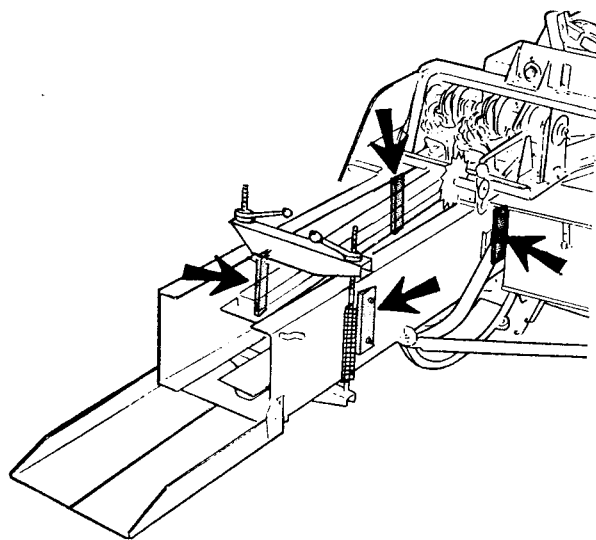

Fig. 16

NOTE : In areas having extremely abrasive soils it may be found that  
 (1) the edges of the packers wear after a season or two's use, and if necessary, they should be replaced. Under these conditions it should be ascertained that the pickup is not positioned too close to the ground causing the crop to be contaminated with soil.

NOTE : When baling very damp hay or silage-type crops it is an advantage to retain the sliding block in the extreme right-hand position to give added lift to the crop.

### BALE DENSITY ADJUSTMENT

Bale density may be adjusted by screwing or unscrewing the two handles which tension the two springs. This alters bale density according to crop conditions.

A relatively slight increase in humidity will cause a big difference in bale density and the operator should frequently check that the proper bale density is being maintained.

In extremely dry or springy conditions, it may be necessary to fit wedge blocks in the bale chamber.

Wedge blocks must not be used in damp conditions as misshapen bales may result.

A kit of 4 wedge blocks is supplied in the tool box.

These blocks must be positioned cutting edge facing forward.

Under very dry conditions, additional density may be obtained by closing in the sides of the bale chamber and locking the nuts C fig 15 and inserting washers between the tailgate supports and support bosses D.

### TAILGATE

On the model 20 baler a split tailgate is supplied which allows the bales to be deflected to the left if the lefthand half of the gate is removed.

Fig. 15 - **A** - TENSION HANDLES  
**B** - STOPS  
**C** - SECURING BOLTS  
**D** - WASHERS

Fig. 16 - WEDGE BLOCKS

## OPERATION

If, on the other hand, a bale sledge is used both halves of the tailgate are retained in position. On the model 15 baler a single piece tailgate is used but holes are provided which allow a wooden deflector piece to be added if required.

On both machines the height of the tailgate can be adjusted by rotating the eccentrically located stops, item (B), fig. 15.

## KNOTTER DISENGAGEMENT LOCK

The knotter disengagement lock is a safety feature to ensure that the operator is not hurt when threading twine, etc. due to accidental movement of the mechanism caused by the packers coming to rest, even though the tractor P.T.O. is disconnected. To lock out the knotter trip pull lever "A" as shown fig. 17, keeping the knotter clutch disengaged.

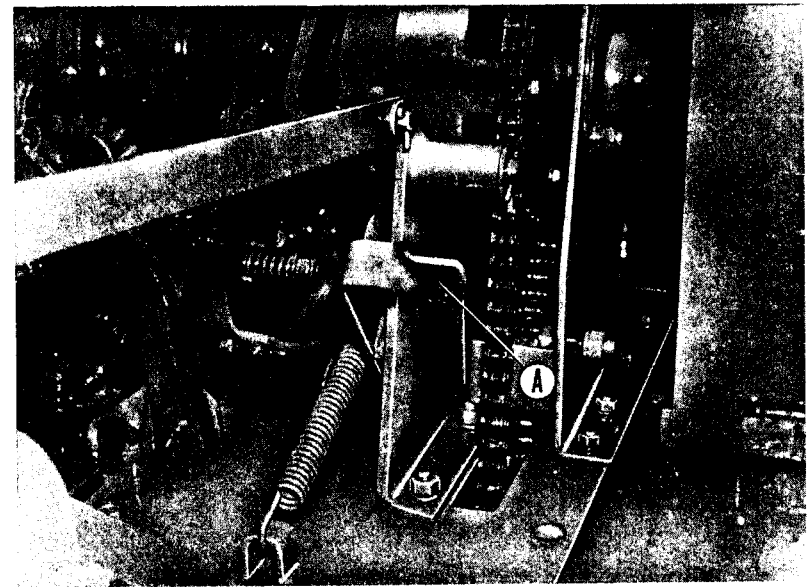

Fig. 17

Fig. 17 - A - KNOTTER DISENGAGEMENT LOCK

**ADJUSTMENT**

Adjustments given in section III "Operation" are the only ones normally undertaken while in the field.

**PICK UP ADJUSTMENT**

- The pick up is balanced by one or two springs. The force to lift the pick up with crop guide must be from 10 to 15 lbs (applied to the crop guide bar). Adjust by nut A fig. 18.
- Ground pick up height can be adjusted as indicated on page 17.
- Crop guide is held down over the pick up by means of a spring located on the right hand shield side.

Spring tension is adjusted by altering the position of the slotted rear anchor bracket. Setting in average conditions must be such that a total force of 5 - 10 lbs (2.3 to 4.5 kg) applied at the tips of the long crop guide tines should equal the resistance of the tension spring.

Initial crop guide height is determined by the position of the adjustable stop located on the crop guide control arm. Normally adjust to obtain a 1"-2" (25 to 50 mm) clearance between underside of crop guide tines and tip of pick up tines.

**PLUNGER ADJUSTMENT**

**A) Skid (n° 15.8 baler up to serial n° 7500) and 6 rollers type plunger (N° 20.8 baler up to serial n° 68000).**

Three plunger rails are adjustable angles (one at the top right-hand side, and one at top and bottom left-hand side), the fourth rail is non-adjustable i.e. bottom right-hand side.

The plunger guide angles provide maximum plunger control with the minimum of frictional drag. Adjusting bolts and locknuts are provided and are illustrated in figure 20.

It must be noted that no attempt must be made to adjust these guide angles without first slackening off the plough bolts which retain the guide angles to the bale chamber.

Correctly adjusted the plunger will slide evenly and freely through out its stroke without stiffness or noise.

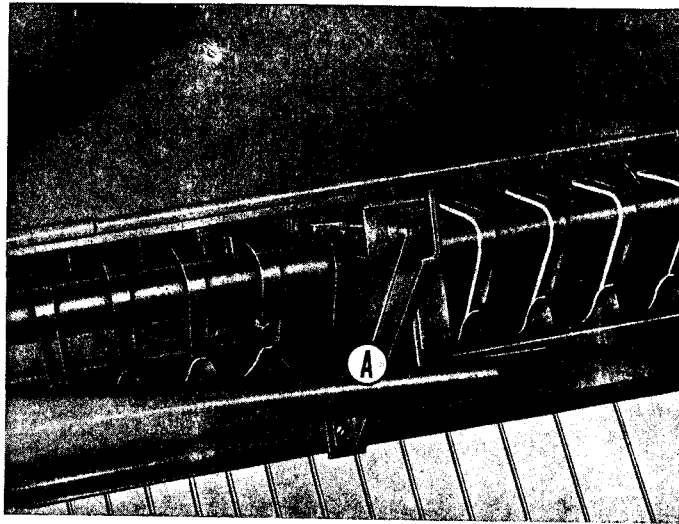

Fig. 18

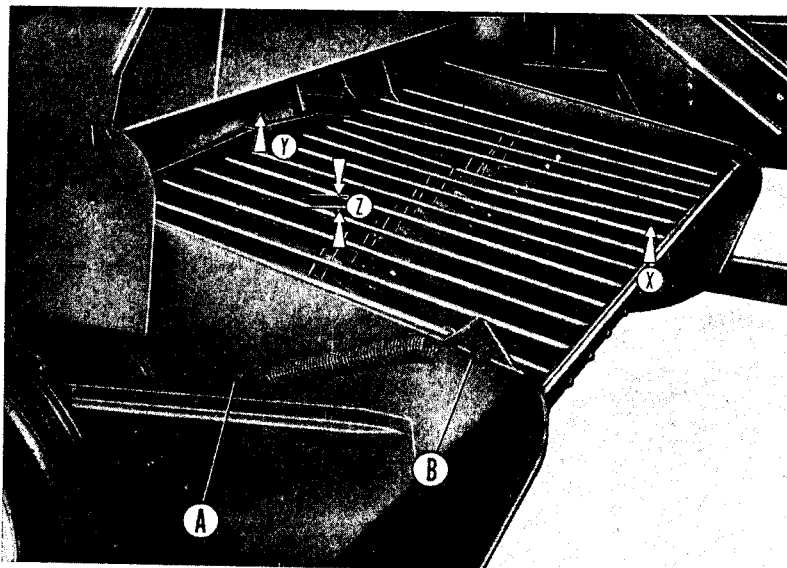

Fig. 19

Fig. 18 - A - NUT ADJUSTMENT

Fig. 19 - A - SPRING TENSION ADJUSTMENT X - 10 TO 15 LBS Z - 1"-2"

B - HEIGHT ADJUSTMENT Y - 5-10 LBS

## ADJUSTMENT

### I) Top right hand plunger guide angle adjustment (vertical clearance adjustment) pads and 6 rollers balers.

- Slacken the 3 bolts securing guide angle on right hand side of the bale chamber.
- Loosen the 3 adjusting locknuts of this angle (on top of the bale chamber).
- Rotate flywheel by hand and tighten successively the 3 adjusting bolts when the plunger is passing under these bolts.

A clearance of .020" to .040" (1.0 mm) must be maintained. Check for this clearance at each of the positions corresponding to the adjusting bolts.

- Tighten lock nuts and securing bolts.
- Slowly rotate flywheel by hand to ensure the plunger slides freely.

### II) Top left hand plunger guide angle adjustment (lateral clearance adjustment) pads and 6 rollers balers.

- Lever the plunger over to the right hand side of the machine so as to take up all clearance.
- Slacken the adjusting bolt locknuts of the left hand guide angles and the securing plough bolts.
- Rotate flywheel by hand and progressively tighten the adjusting bolts to obtain a clearance of .020" to .040" between left hand guide angles and plunger at the rear of the machine and .020" to .080" at the front of the machine.
- Tighten locknuts and securing bolts.
- Check that plunger slides freely.

### Bottom left hand plunger guide angle adjustment (N° 15 baler Pads).

Adopt a similar procedure as above. Check again that the plunger slides freely.

**Overtightening of the plunger guide angles could cause overheating and scoring. While too much clearance may cause abnormal stress on the shear blades, untidy bale cuts, and noisy running.**

### Bottom left hand plunger guide angle adjustment (N° 20 baler Rollers).

Tighten the screws until the angle is close to the rollers without play but the plunger must move freely. Maxi play : .002" (.05 mm).

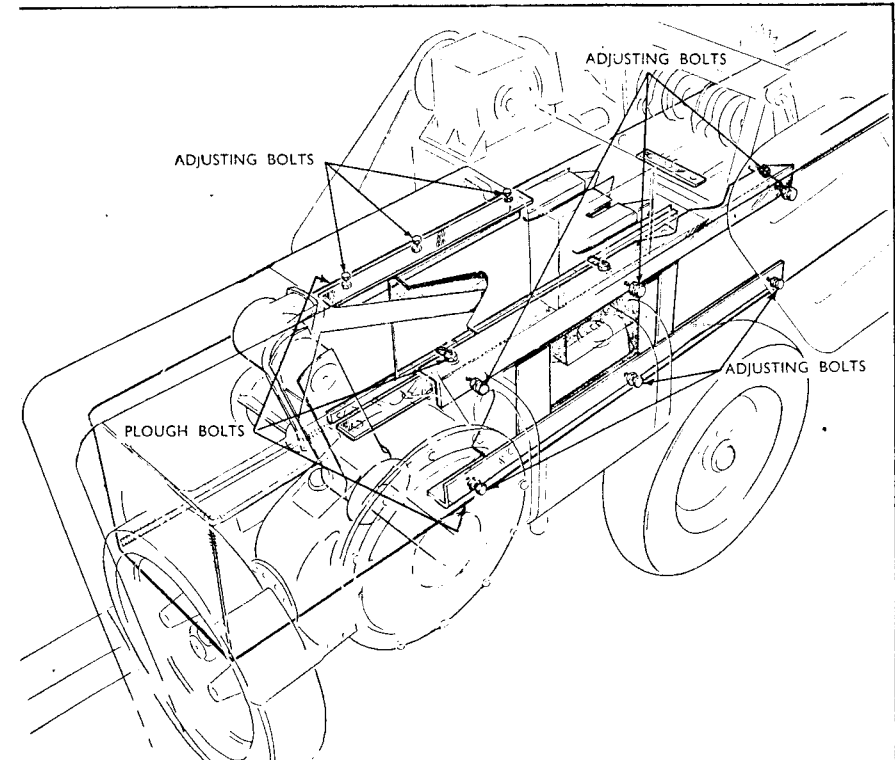

Fig. 20

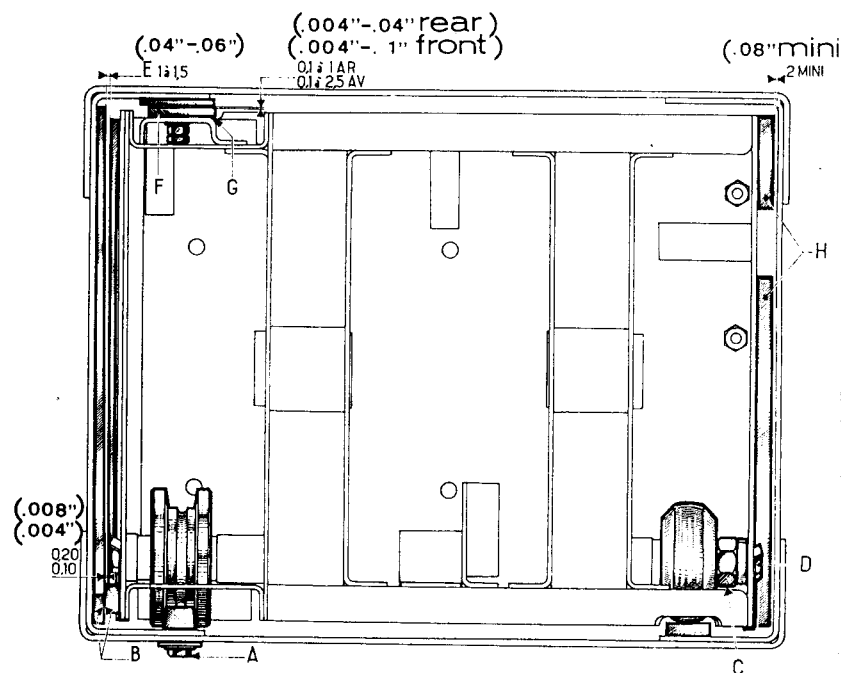

Fig. 20 B

- B) 3 Rollers plunger** - N° 15.8 baler from serial n° 7501  
 - N° 20.8 baler from serial n° 68001

The adjustments of 3 rollers plunger guides on MF 15 or MF 20 differ from those described for Pads or 6 rollers type plunger. The piston moves on two rails of which only one is adjustable. A pad on the upper right permits vertical adjustment.

#### Guide rail for the right hand side roller

Untighten slightly the eleven screws A holding the guide rail so that the latter can be moved without excessive play.

**REMARK** — Ten screws are mounted on an iron strap below the bale chamber the eleventh is further out and locks a square plate. This last screw should not be forgotten during the slackening off nor during the tightening. Should the screw be completely removed the square plate must be set back in place.

Push completely the plunger to the right so that there is no play in B. Tighten the screws while keeping a no-play position on the full travel of the plunger.

When the clearance in B is zero the clearance between shear blades is .1 mm to .2 mm (.004" to .008") at the bottom.

#### Adjusting the plunger horizontally

The level of the plunger which commands the shear blades top clearance, may be adjusted with the left roller.

It is fitted to on a excentered shaft, the position is adjusted by the nut C.

To adjust the shear blade top clearance, move back the tab washer and slacken lightly the screw D.

Turn the nut C to raise or lower the plunger until the top clearance E is within 1 and 1.5 mm (.04" and .06") tighten back the screw C and fold back the locking plate.

To be certain of a correct adjustment, move the plunger by hand on its whole travel.

**NOTE** — The connecting rod is tight and may tend to raise the left side of the plunger. Therefore before any adjustment, the connecting rod should be turned by hand to correcty position the left side roller on its rail.

#### Upper pad rail

The plunger is held vertically by a pad sliding on a rail. The clearance between both must be within 0.1/1 mm (0,004" /0,04") when the plunger is in compression and within 0,1 2,5 mm (0,004" 0,1") when in forwardmost position.

## ADJUSTMENT

The adjustable pad F is fitted on the plunger. To adjust, place shims G under the pad. This operation is seldom needed but when changing of the plunger or rails. It may be necessary to remove the plunger.

### Blanking plates

The blanking plates H are not guides but prevent crop from going between plunger and bale chamber.

There must be a minimum clearance of 2 mm (0,08") between them and the plunger on the full travel length. They are secured by bolts through holes permitting an easy adjustment.

### SHEAR BLADES (refer to fig. 21)

The shear blades or knives comprise one fixed and one moving (plunger) knife. Both blades are retained by countersunk screws and are shimmed to provide an initial clearance of .004" (0.1 mm) to .021" (0.56 mm) when the plunger is pushed hard over to the right hand side of the machine.

The blades must be parallel and must not project beyond the plunger or bale chamber bearing surfaces.

### N° 15 baler (Pad plunger)

As the plunger sliding clearance is between .020" (0.5 mm) and .040" (1 mm), the total shear blades clearance must be between .024" (0.5 mm) and .062" (1.5 mm) when the plunger is held over to the left hand side of the machine.

### CHAIN TIMING

When chains have been removed for lubrication or retiming, care must be taken when replacing, to time them correctly because the feeding and tying mechanisms must be exactly timed in relation to the plunger.

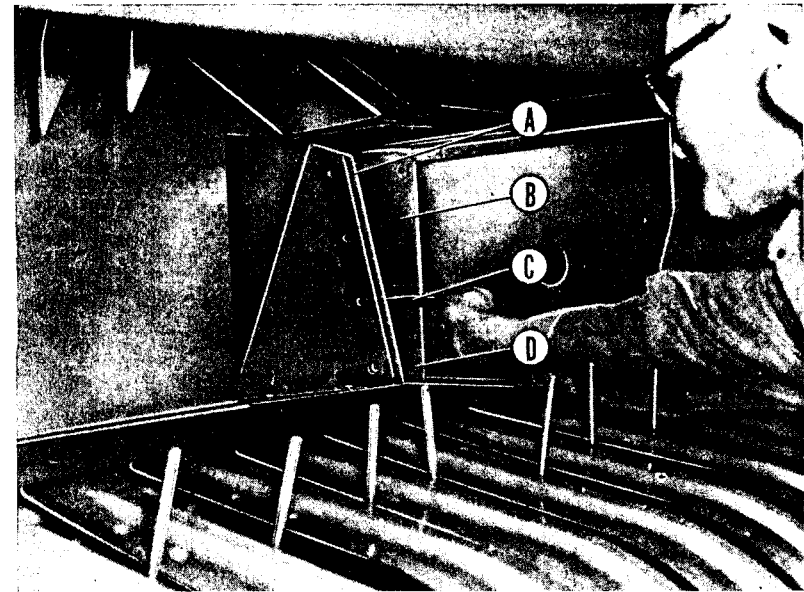

Fig. 21

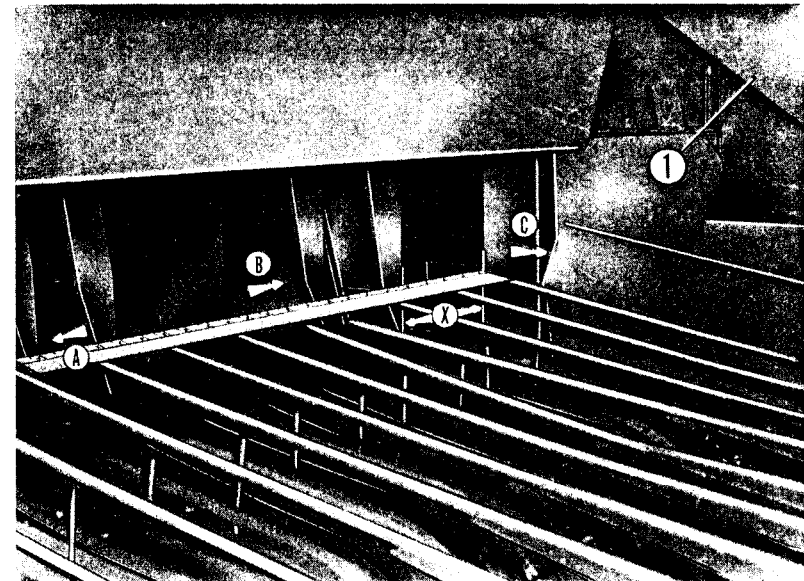

Fig. 22

Fig. 21

- A - FIXED BLADE
- B - MOVING BLADE
- C - GAUGE
- D - SECURING SCREW

Fig. 22

- 1 - PACKER CHAIN SHIELD
- A - BACKLASH TAKEN IN THIS DIRECTION
- B - DIRECTION OF TRAVEL
- C - PLUNGER ON RETRACTING STROKE
- X - 6 to 9"

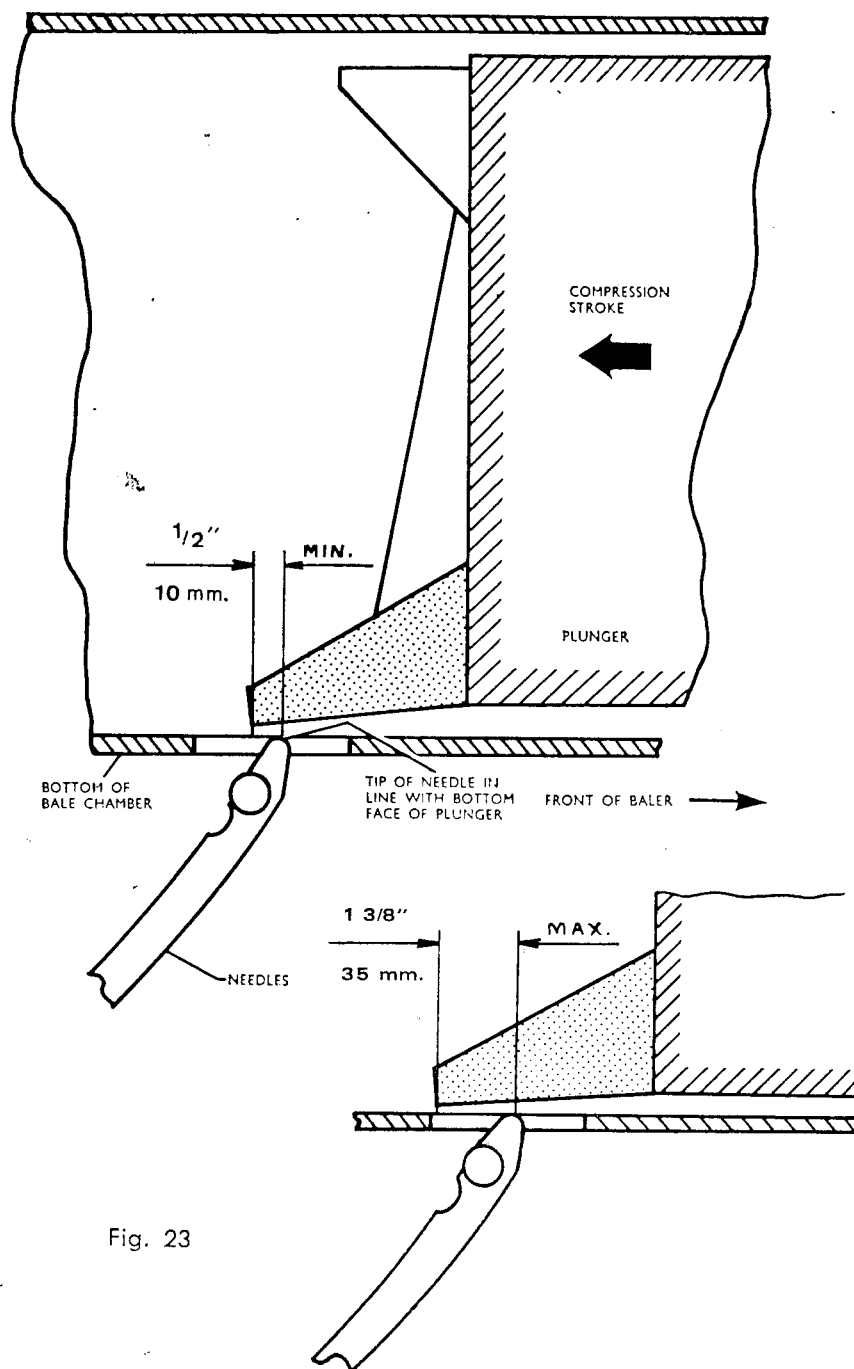

Fig. 23

### I) Packer crank drive chain.

Should the packer crank drive chain have been removed for any reason it must only be refitted with packer cranks parallel to each other.

### II) Packer timing.

The packers must be accurately timed in relation to the plunger. The correct timing is shown in fig. 22.

- Set the wooden packer fingers in the centre holes as shown in fig. 6.
- Set the adjusting block (A, fig. 14) to the right-hand position.
- When the machine is rotated to the position where the tip of the shearblade is in line with the front packers the distance  $x$  (fig. 22) should be 6" - 9".

If timing is incorrect proceed as follows:

- Remove chain shield 1, then driving chain.

**CAUTION** — No attempt must be made to remove drive chain unless the packer fingers are in their lowest position.

- Turn baler flywheel in arrowed direction until the plunger is on its return stroke, moving towards the baler drawbar and the lower edge of the plunger shear blade is in line with the forward edge of the front wooden packer finger.
- Draw chain tight to eliminate sag and offer it up to the underside of the packer gearbox sprocket. Should the chain pitch not coincide with the gearbox sprocket pull the steel packer finger towards the R.H. side of the machine. This will cause the gearbox sprocket to turn and permit the chain to engage with the sprocket teeth. It is important to note that the sprocket must be turned the minimum amount necessary to engage the chain and the chain must not be allowed to sag. Guide the chain over the packer gearbox sprocket, under the chain tensioner and place the ends together on the crankshaft sprocket. Fit chain link ensuring that the closed end of the spring link leads in the direction of rotation.
- Adjust chain tensioner.
- Turn baler flywheel in the arrowed direction and re-check timing.
- Replace chain guard.

Fig. 23 - NEEDLE TIMING



## ADJUSTMENT

### III) Needle timing.

— Check the needles for correct adjustment (see page 36).

As shown in fig. 23 the needle tips should be protected by the lower points on the plunger to the extent of 1/2" to 1 3/8".

If the needle timing is not correct by a **few** chain pitches:

Remove the upper intermediate sprocket close to the knotter clutch. move the chain around the knotter shaft sprocket one pitch at a time, rechecking timing at each pitch change. Replace sprocket when timing is correct and adjust chain tension.

If the driving chain has been removed proceed as follows:

Rotate flywheel in direction of arrow until the plunger is moving on the compression stroke beyond the plunger stop. Hold the flywheel in this position.

— Push needle gate forward until needle tips are level with lower inner face of bale chamber.

— Bring plunger forward until tips of lower plunger point are 3/4" (20 mm) behind needle tips (basic adjustment). Hold flywheel and needle gate in these positions.

— Engage trip mechanism by spinning metering wheel.

— Rotate knotter clutch sprocket in normal direction until knotter clutch is felt to engage. Hold knotter clutch sprocket in this position.

— Connect up knotter drive chain ensuring that the forward run of chain is held taut and the plunger, needles and knotter shaft are not disturbed.

**NOTE** — When chain and sprocket pitches do not coincide, remove the four bolts securing the knotter sprocket to the knotter hub and rotate the sprocket through 45° clockwise or anticlockwise. Secure the attaching bolts in the most suitable position and connect up the chain.

— Adjust chain tension (refer to page 70).

— Rotate flywheel by hand and complete knotter cycle.

— Retrip knotter mechanism, rotate flywheel by hand and check needle timing. If the timing is correct the needles should enter the bale chamber at a point between 1/2" to 2 3/4" (10-70 mm) behind the tips of the plunger lower points when the plunger is on compression stroke.

For needle safety stop adjustment refer to page 65.

## SECTION V

# TWINE KNOTTER ADJUSTMENTS

It should be noted that if a few knots are missed during the first few working hours of any one season that it is inadvisable to make any immediate adjustment.

Stiffness of the working parts or rust preventative may interfere with the proper working of the machine and in particular any roughness on the bill hook might interfere with the stripping of the knot.

In order to deal in a methodical manner with knotter adjustment the sequence of operations when attempting to find a fault which is not very obvious should be as follows:

(a) Check that the twine is taken through all the guides from the twine box to the needles in the proper manner. See pages 14-15.

(b) Check that the timing and positioning of the needles is correct. See pages 30-33-36.

(c) Check that the positioning and adjustment of the twine fingers is correct. See pages 40-43.

Make any knotter adjustment only after the above checks have been made.

It is important to deal with any problem in the above sequence as the twine tensioning effects the needle positioning and the needle positioning and timing effects twine finger operation. It is more often the case that needles or twine fingers require adjustment rather than the knotter itself.

### SETTING THE NEEDLES

Correct needle adjustment is essential to obtain satisfactory knotter operation.

There are three needle adjustments facilitated by tripping the knotter mechanism and rotating the flywheel by hand or alternatively by disconnecting needle drive connecting rod allowing the needles to come upwards into the knotter.

#### 1) Needle travel

The travel of the needle past the twine disc must be  $2\frac{1}{2}'' - 2\frac{3}{4}''$  as shown at "X", fig. 24. This adjustment is made by adjusting the yoke B fig. 26, on the connecting rod linking the needle gate to the knotter shaft arm.

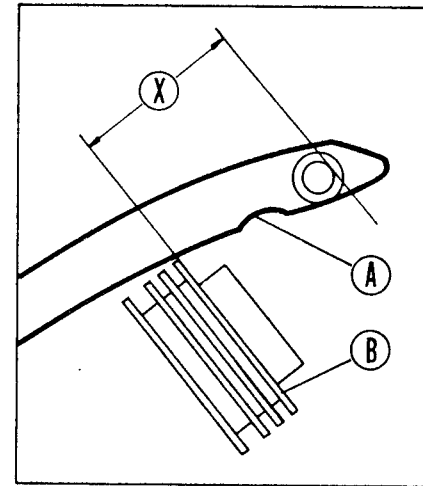

Fig. 24

#### 2) Twine disc clearance

The clearance between the inside edge of the needle and the outer edge of the twine disc should be approximately  $\frac{1}{8}''$  (2-4 mm).

The adjustment to obtain this requirement is made by loosening one of the retaining bolts on the needle gate and tightening the other. This is best done gradually by leaving reasonable tension on the bolt being loosened. Y fig. 25 shows the clearance.

#### 3) Side adjustment

The right-hand side of the needle should slightly graze the knotter frame so placing the twine correctly in the twine disc. If necessary adjust the needles laterally on the needle gate. The securing lugs of which are slotted to allow this movement.

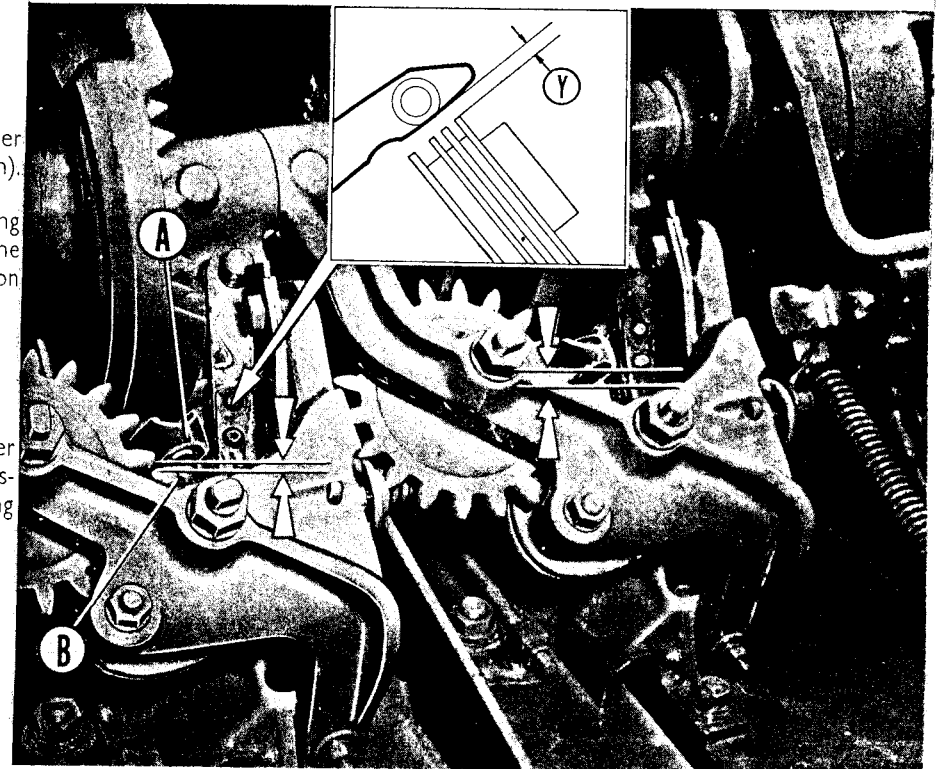

Fig. 25

Fig. 24 - A - NEEDLE B - TWINE DISC X -  $2\frac{1}{2}''$  TO  $2\frac{3}{4}''$   
 Fig. 25 A - NEEDLE B - TWINE DISC Y -  $\frac{1}{8}''$

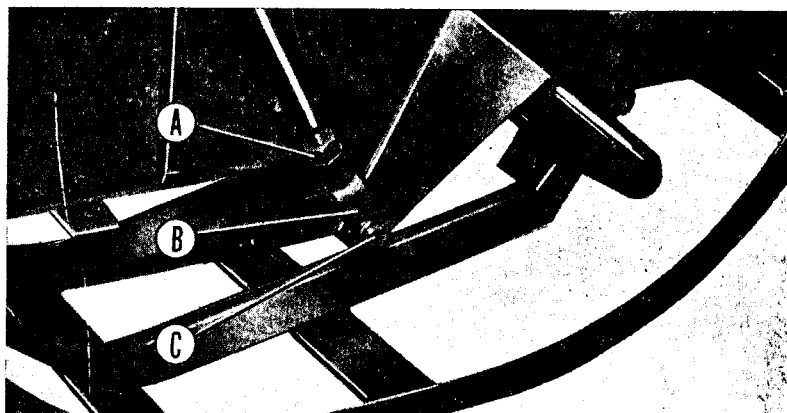

Fig. 26

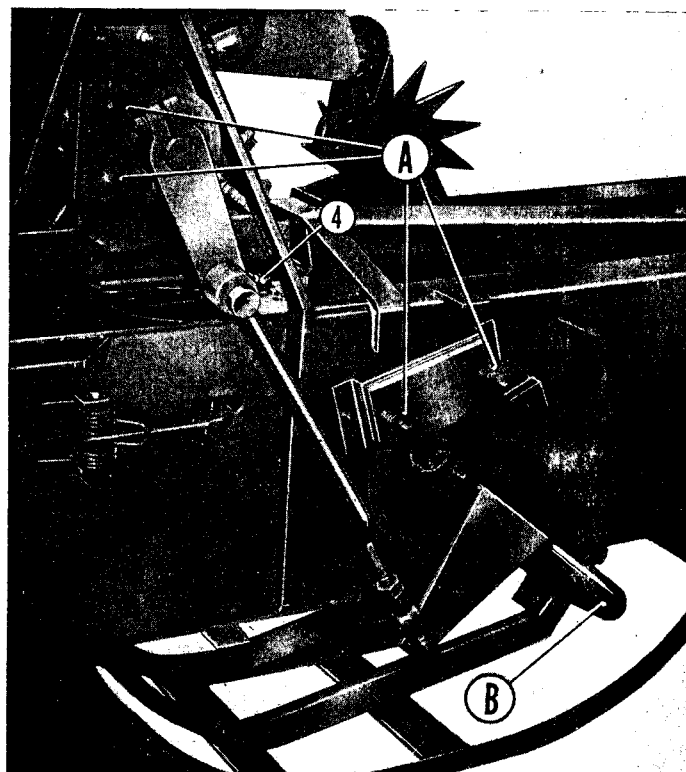

Fig. 27

### NEEDLE TIMING

After any adjustments of needle travel it is essential to recheck the needle timing as shown on pages 33-34.

### KNOTTER AND NEEDLE GATE BRAKES

Damping brakes are fitted on the left-hand side of the machine to prevent improper movement of the knotter and needle mechanism and to avoid the needle and knotter beginning a second cycle inadvertently after a knot has been made.

Adjustment of these brakes is obtained by tightening the nuts A, fig. 27.

In normal conditions the knotter shaft brake must be tightened so that it is hard to turn by hand when the driving chain and connecting rod to needle gate are in the position shown in fig. 27.

The needle brake must be sufficiently tight that a force of 10 lbs is required at point B, fig. 27, to push the needle gate down and the needles into the knotter with the connecting rod disconnected.

Fig. 26 A - LOCK NUT B - YOKE C - PIN

## TWINE KNOTTER

### TWINE FINGERS

The proper adjustment of the twine fingers is very important on the 15 and 20 balers.

- 1) The tip of the twine fingers should be within  $1/16''$  (1-2 mm) of the needle to ensure catching the twine as shown in fig. 28. This adjustment is made by moving the pivot bolt (A, fig. 29) along the slot provided.
  - 2) The clearance x fig. 29, with knotter bracket item C, fig. 29, when twine finger is fully across with normal twine tension should be the minimum possible consistent with a maximum protrusion (Y, fig. 30) of  $3/16''$  of the tip of the twine finger.
- This adjustment is made by unscrewing or screwing up the connecting rod, item B, fig. 29 after removal of the cotter pin and return spring, and after slackening off the locknut.

### KNOTTER ADJUSTMENT

After all the above adjustments are correct twine can be threaded into the needles and the machine turned over by hand when the following sequence of events as depicted in figs. 31-32-33-35 and 36 will take place.

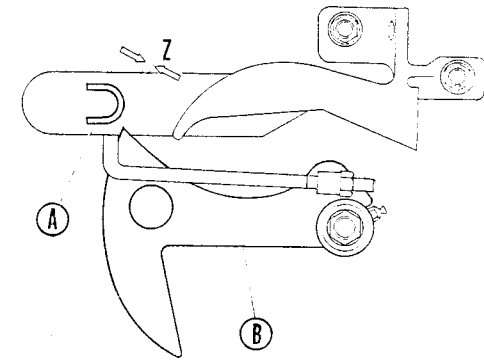

Fig. 28

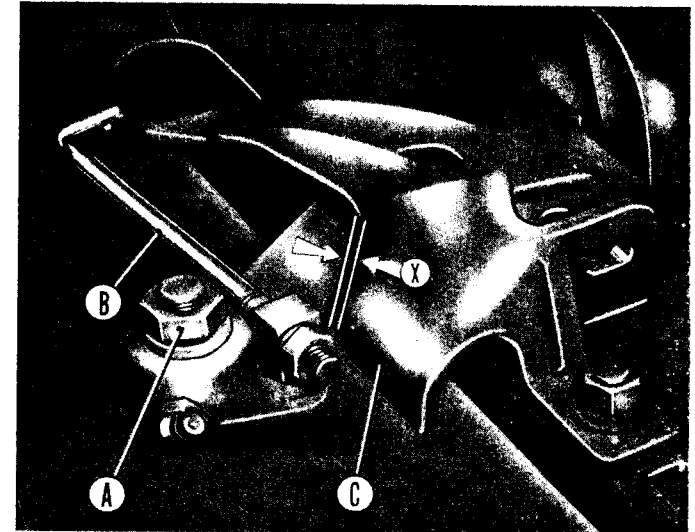

Fig. 29

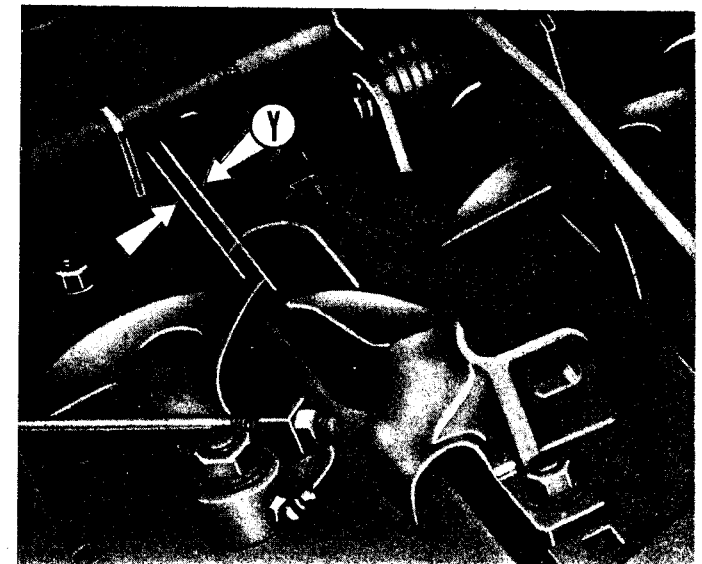

Fig. 30

- Fig. 28 - A - NEEDLE B - TWINE FINGER Z -  $1/16''$  MAX.  
Fig. 29 A - TWINE FINGER PIVOT BOLT LOCK NUT C - KNOTTER BRACKET  
B - TWINE FINGER CONNECTING ROD

Fig. 30 - Y -  $3/16''$  MAX.

Fig. 31

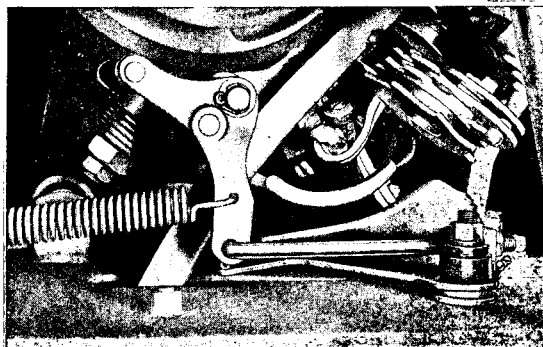
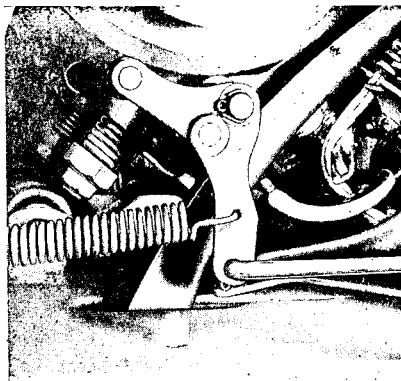
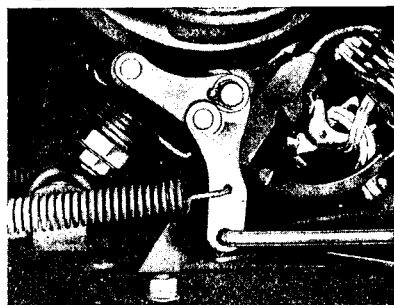

Fig. 32



Fig. 33

A ▶  
◀ B



**TWINE GRIP ADJUSTMENT**

Fig. 31 shows the twine being gathered and positioned by the twine finger. Figs 32 and 33 show the twine being twisted by the bill hook and eventually gathered by the bill hook with the correct position of the knotter disc ensuring that this takes place. The twine disc must be adjusted so that both twines are gathered by the bill hook as shown in fig. 33 B which is an enlarged view taken from fig. 33 A.

This is important, and it should be noted that this is the **only** correct twine disc positioning. If the twines are not gathered cleanly by the bill hook the disc may be required to be advanced or retarded which may be done by turning the eccentric stud, item D, fig. 34.

The procedure is as follows:

- (a) Loosen locknut, item (C), taking care not to inadvertently rotate eccentric (D).
- (b) Rotate eccentric (D) so causing the twine disc to be advanced or alternatively causing increased clearance between the teeth of the gear item (A) and the gears on the twine disc. Lever the twine disc round (i.e. retarding) until the backlash is taken up. Obtain the correct positioning of the twine as shown in fig.33 by trial and error. Ensure that the locknut is tightened properly, after readjustment.

**NOTE** — Two positions of the eccentric stud give the same setting on the twine disc. The upper position which gives the greater contact area on the knotter cam and gear teeth should be used.

The grip is increased by tightening up setscrew (H) fig. 34. Too loose an adjustment will allow the twine to be pulled out of the grip when the bale is being formed. Too tight an adjustment will not allow the twine to be partially withdrawn from the grip while the knot is being formed.

Should synthetic twine be used it may be necessary to slacken off the twine grip slightly.

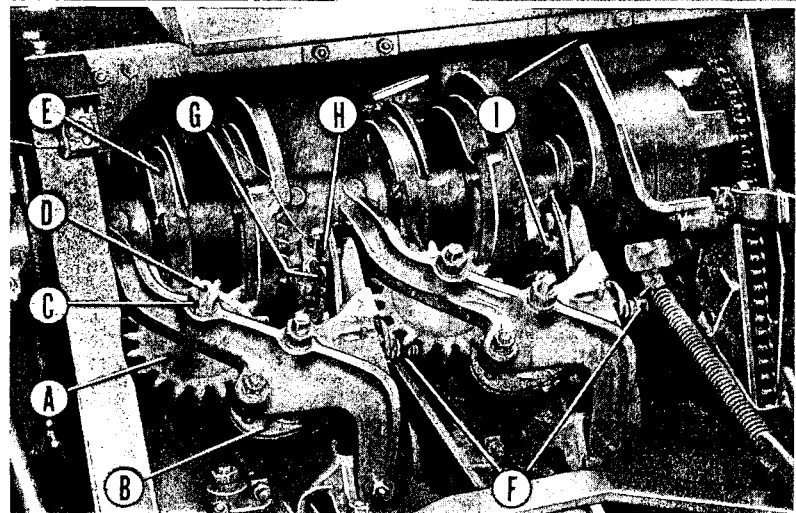

Fig. 34

- |                       |  |
|-----------------------|--|
| A - INTERMEDIATE GEAR | F - BILL HOOK - AWN PRESSURE ADJUSTING NUT |
| B - TWINE DISC        | G - TWINE GRIP                             |
| C - LOCK NUT          | H - TWINE GRIP ADJUSTING SET SCREW         |
| D - ECCENTRIC         | I - NEEDLE                                 |
| E - CAM               |  |

**BILL HOOK JAW PRESSURE ADJUSTMENTS**

The bill hook jaw cam closes the jaw of the bill hook as shown in fig. 35 to ensure that ends of the twine are firmly held during stripping of the knot. The grip of the jaw may be tightened or loosened by adjusting the pressure of the spring (F) fig. 34 which acts on the cam. Prior to any adjustment make sure that the jaw is free to move in the bill hook. If trouble is being met with in pulling both ends through the knot (or alternatively, one end through, and one end bowed) make small adjustments at any one time.

**TWINE KNIFE ADJUSTMENT**

The knife is secured on the stripper arm which strips the knot from the bill hook after the twine has been cut.

The twine knife must be adjusted so that when the stripper arm is at rest it should be approximately  $\frac{3}{16}$ " -  $\frac{1}{4}$ " (5 mm - 7 mm) from the inside of the twine groove as shown in fig. 37. The twine knife may be adjusted in this direction by virtue of the slotted holes provided. If this dimension cannot be obtained it is likely that the stripper arms have been bent.

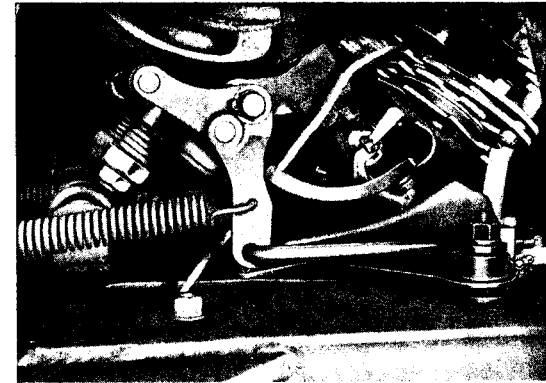

Fig. 35

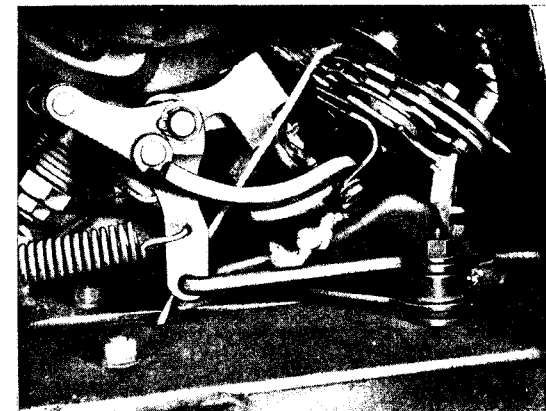

Fig. 36

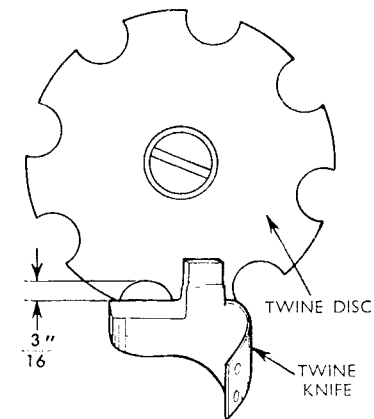
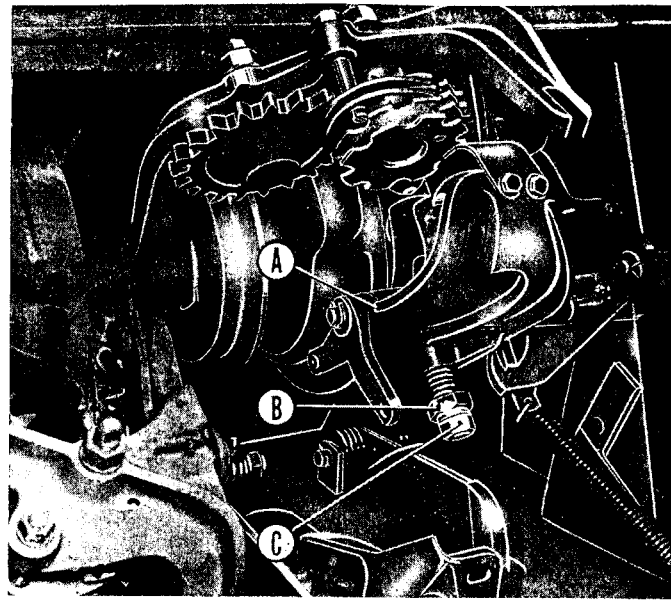

Fig. 37

Fig. 38



**STRIPPER ARM SPRING TENSION**

The knife arm is spring loaded. The tension spring should be adjusted by the nut item (B), fig. 38, and locked into position by the locknut item (C), so that a pressure of 6-8 lbs (3- 3 1 2 kg) exerted behind the knife arm at the point (A) will just move the arm from its " at rest " position.

**KNOTTER FRAME ADJUSTMENT**

A 5.2" ± 0.04" (132 mm ± 1) clearance between the knotter frame pin and the top of the bale chamber must be maintained (Z fig. 39).

To adjust, release the securing nut, raise or lower the frame assembly to obtain the correct clearance then tighten the nut.

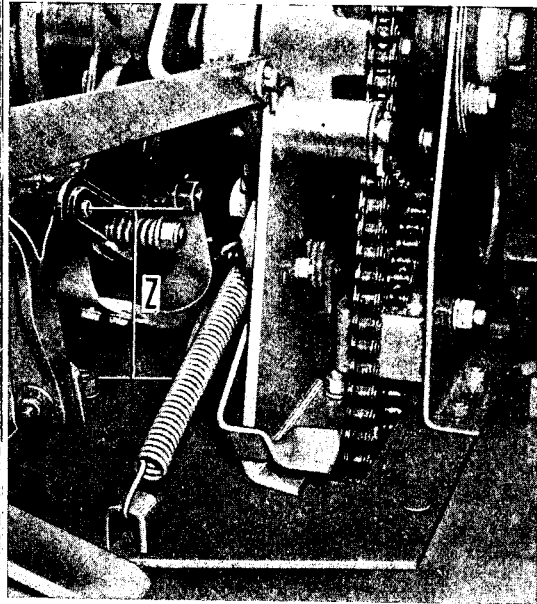

Fig. 39

**TRIP MECHANISM**

Spacers are inserted between the metering wheel bracket and the support on the bale chamber to obtain the correct position of the metering wheel and metering arm. As shown in fig. 40 when the arm (A) is being reset and is dropping, the distance from the face of the roller should be approximately 1/16" (2 mm).

Fig. 40

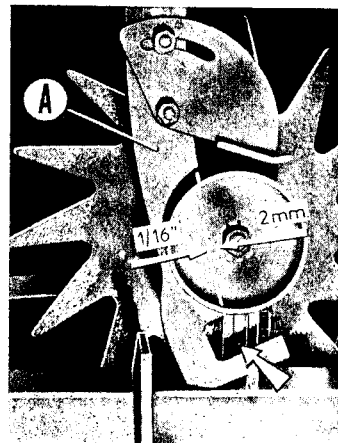

Fig. 38 - A - KNIFE ARM  
 B - ADJUSTING NUT  
 C - LOCK NUT

Fig. 39 - Z - 5.2" ± 0.04

**CAUSES OF MIS-TYING**

By examination of the loose bands of twine where mis-tying is occurring, a good deal of information can be obtained concerning causes.

Most tying faults can most easily be diagnosed by slowly turning the machine by hand with crop in the bale chamber and watching the tying action. It may be necessary to remove front and side knotter guards for this purpose.

**FAULT:**

Bale end of the twine knotted and the needle end free and clean cut (see fig. 41).

**Possible Cause - 1:**

Needle timing in relation to the plunger may be too late, causing the needles and tying to be so late that the plunger returning from the compression stroke allows hay to spring back and push twine out of reach of the twine finger. Either or both of the twines may not be brought into engagement of the bill hook.

**Remedy:**

Re-time the needles.

**Possible Cause - 2:**

Even though the machine settings are correct, the hay springs back and pushes the twine from under the twine finger.

**Remedy:**

Check that the check hooks work freely and that the springs are not too weak or broken. Check clearance between twine finger and needle is approx. 1/16.

**Possible Cause - 3:**

Twine fingers not travelling far enough, with the result that the needle's twine is not located correctly against the bill hook.

**Remedy:**

Set the twine fingers closer to the knotter bracket (see fig. 29, 30).

**Possible Cause - 4:**

Needle twine not being gathered by the bill hook jaw due to the twine disc being too far retarded.

**Remedy:**

Reset twine disc.

**Possible Cause - 5:**

Check the end play of the bill hook and, if necessary, replace the pin securing the bill hook pinion to the bill hook if this is worn, or add shims between the bill hook pinion and the rear inside surface of the knotter frame if the pinion is worn. Check that the cam on knotter frame is not grooved or worn where the roller for bill hook jaw makes contact.

**Possible Cause - 6:**

The needle end of the twine is not gathered by the twine finger due to being deflected by crop in between the top of the plunger and the bale chamber.

**Remedy:**

Add shims under the four spacers on top of the plunger or replace wear pads on the plunger if severely worn to minimise the space between the spacers and the inner surface of the bale chamber.

**FAULT:**

Needle end of twine is knotted and bale end free but frayed usually too short (see fig. 42).

**Possible Cause - 1:**

Bales too tight or too damp, preventing the twine from being pulled through between the bales.

**Remedy:**

Slacken off bale tightness.

**Possible Cause - 2:**

A snarl in the twine gripped by the twine disc, causing the twine to break.

**Remedy:**

Check the smoothness of all parts touched by the twine and twine tensioner is correctly set. Make sure that the twine is dry.

**Possible Cause - 3:**

Sharp edges in the twine disc cutting the twine due to needles touching and burring the edges of the discs.

**Remedy:**

Remove burr and polish smooth. Reset needles.



## TWINE KNOTTER

### Possible Cause - 4:

Sharp edges on the knife arm (fig. 38), twine knife screws knotter bracket or the bale chamber causing fraying of the twine.

### Remedy:

Smooth off all surfaces touched by the twine.

### Possible Cause - 5:

Bale tightener and twine grip excessively tight, not allowing enough twine to be pulled between the bales and withdrawn from the twine grip to form the knot.

### Remedy:

Slacken off the twine grip slightly to allow enough twine to be pulled through the grip at the instant the knot is formed.

### Possible Cause - 6:

Knife arm jumping at each stroke of the plunger, causing the twine to be partially cut before the bale is formed.

### Remedy:

Check for proper position of twine under bracket (fig. 29) and check knife arm tension spring.

### Possible Cause - 7:

Trash gathered behind knife arm forcing it forward and cutting or fraying the twine.

### Remedy:

Remove trash.

### Possible Cause - 8:

The twine left by the retracting needle jumps the point of the knotter bracket item (c) fig. 29 so allowing the bill hook to miss the twine.

### Remedy:

Check that the twine is threaded through all the twine guides and that the tensioner plate is functioning correctly.

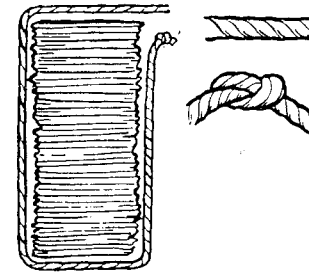

Fig. 41

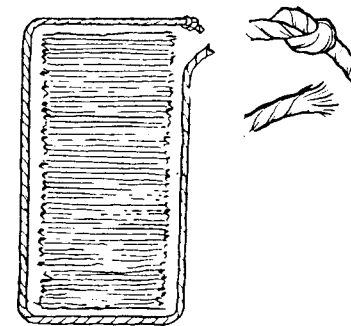

Fig. 42

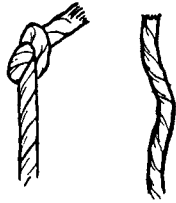

Fig. 43



Fig. 44



Fig. 45



Fig. 46



Fig. 47



Fig. 48



Fig. 49

**FAULT:**

Needle end of twine knotted, but bale end free but cleanly cut (see fig. 43).

**Possible Cause - 1:**

Twine slipping from the twine disc.

**Remedy:**

Tighten the twine disc retainer spring.

**Possible Cause - 2:**

Twine retainer spring broken or damaged.

**Remedy:**

Replace spring.

**Possible Cause - 3:**

Bale twine jumping over bill hook, generally at the commencement of the bale.

**Remedy:**

- (a) See that the twine is properly threaded in the tension plate and through all twine guides.
- (b) See that the knife arm is correctly tensioned and does not bounce allowing the twine to jump from the hook.

**Possible Cause - 4:**

Twine disc too far advanced, causing the toe of the bill hook to miss the twine.

**Remedy:**

Reset the twine disc.

**FAULT:**

Both ends untied but cleanly cut (fig. 44).

**Possible Cause - 1:**

Twine knife set too high and cutting too soon.

**Remedy:**

Reset twine knife so that the cutting edge is approximately 3/16" (5 mm) from the inside of the twine disc groove (see fig. 37).

**Possible Cause - 2:**

Knife arm damaged or bent.

**Remedy:**

Replace the knife arm.

**Possible Cause - 3:**

Neither end is pulled sufficiently through the loop when stripping off the bill hook with the result that the knot becomes undone before or after the bale leaves the bale chamber. This is due to insufficient bill hook jaw pressure.

**Remedy:**

Tighten spring item (f) (fig. 34) to increase bill hook jaw pressure.

**FAULT:**

Knot unformed and both ends frayed (fig. 45).

**Possible Cause - 1:**

Twine grip and bale too tight so that no twine can be drawn from around the bale or from the twine disc to form the knot.

**Remedy:**

- (a) Slacken off twine grip slightly.
- (b) Slacken off bale tightener slightly.

**FAULT:**

Knot partially formed but breaks near the knot (fig. 46).

**Possible Cause - 1:**

Knot hanging on to the bill hook too long, due to twine knife being too far back.

**Remedy:**

Adjust the twine knife so that the cutting edge is approximately 3/16" (5 mm) from the inside of the groove in the twine disc (fig. 37).

**Possible Cause - 2:**

Bill hook jaw too tight, the knot failing to be stripped from the bill hook cleanly.

**Remedy:**

Check that the bill hook is smooth and polished, if so reduce bill hook jaw pressure.

**Possible Cause - 3:**

Knife arm not moving sufficiently due to damage or wear of the roller or cam.

**Remedy:**

Examine and replace parts if necessary.

**Possible Cause - 4:**

Blunt or chipped twine knife.

**Remedy:**

Regrind the knife and reset so that the cutting edge is approximately 3/16" (5 mm) away from the inside of the groove in the outer twine disc.

**FAULT:**

The knot properly formed but the bale twine broken and frayed (fig. 46).

**Possible Cause - 1:**

The twine finger failing to return to its correct "at rest" position, and fouling the twine due to:

- (a) Twine finger bent, fouling the knife arm, in its forward position.
- (b) Twine finger bent and fouling the bale chamber.
- (c) Twine finger rusted or sticking on the trunnion.

**Remedy:**

- (a) and (b) Remove the twine finger and straighten.
- (c) Free the twine finger and lubricate, also check the spring tension.

**Possible Cause - 2:**

Knotter not completing a full cycle, allowing the twine finger to remain in the forward position and allowing the twine to be caught over the top of the finger.

**Remedy:**

- Check operation of trip mechanism.
- Check freedom of the needles and linkage.
- Check smooth operation of knotter brake and needle brake.

**Possible Cause - 3:**

Completed knot being trapped between the knotter bracket (fig. 30) and the top of the bale chamber.

**Remedy:**

Check that the bolts holding the knotter bracket are tight and that the top of the bale chamber has not been damaged.

**FAULT:**

Bow knot with tails long and frayed (fig. 47).

**Possible Cause - 1:**

Blunt knife which results in a tearing instead of cutting action.

**Remedy:**

Sharpen knife.

**Possible Cause - 2:**

Knife set too far back so that cutting is retarded.

**Remedy:**

Adjust the knife; cutting edge should be approximately 3/16" (5 mm) from the inner surfaces of the groove in the outer twine disc (fig. 37).

**FAULT:**

Single bow knot with long end bowed and possibly broken (fig. 48).

**Possible Cause - 1:**

Long end caused by insufficient tension on the twine grip.

**Remedy:**

Tighten the twine retainer and slacken off the bill hook pressure.

**Possible Cause - 2:**

Broken bow due to too much pressure on the bill hook, due to probable over-tightening of the hook in attempting to pull the long end through.

**Remedy:**

Tighten the twine retainer and slacken off the bill hook pressure.

**FAULT:**

Double bow knot (fig. 49).

**Possible Cause - :**

Insufficient bill hook pressure.

**Remedy:**

Increase bill hook pressure.

**FAULT:**

Either one or both knotters tie an extremely long bale, not due to faulty knotter trip, but due to twine not being gathered by the twine disc.

**Possible Cause - 1:**

Due to faulty setting or travel of the needles.

**Remedy:**

Check the travel or position of the needles as instructed under "Needle-Adjustment".

**Possible Cause - 2:**

Due to faulty setting of the twine disc.

**Remedy:**

Check the setting of the twine disc and ascertain the lock nut on the eccentric stud is tight (fig. 34).

**Possible Cause : 3:**

Due to curls or snarls in the twine.

**Remedy:**

Check that the twine tensioner is correctly set.

**FAULT:**

Both ends untied a short length of twine with frayed end being retained by the knotter.

**Possible Cause - 1:**

Sharp edge in needle eye cutting twine as needle travels out of bale chamber.

**Remedy:**

Smooth the eye in the needle.

SECTION VI

## SAFETY DEVICES

Many safety devices are fitted to N° 15 and 20 pick up balers to prevent damage.

### BALER P.T.O. SHAFT

Three safety devices are fitted to the flywheel.

#### 1) An overload clutch

This slip clutch is adjusted so as to slip should overload occur. Do not modify spring tension without reason.

To check and adjust overload clutch proceed as follows:

- Set plunger stop so that it penetrates into bale chamber by tripping knotter clutch and pushing down needle gate.
- Rotate flywheel until plunger is in contact with stop.
- Slip the clutch for a few seconds to free the clutch linings.
- On N° 20 baler remove the guard shield from centre universal joint and support front end of the P.T.O. shaft ensuring that both shafts permit a straight drive line to the flywheel.
- Insert 5 feet of 1" steel bar through the yoke of the centre universal joint on N° 20 baler and through the front one on N° 15 baler.

Attach a spring balance to the bar at a distance of 4ft from the yoke as shown in figure 51.

**NOTE** — It may be necessary to remove the grease nipple from the yoke.

- Apply an even pull to the spring balance at right angles to the bar.

The clutch should slip when a spring balance reading between 112 lbs (51 kg) and 133 lbs (60 kg) is registered.

Fig. 51 - X - 4 FT

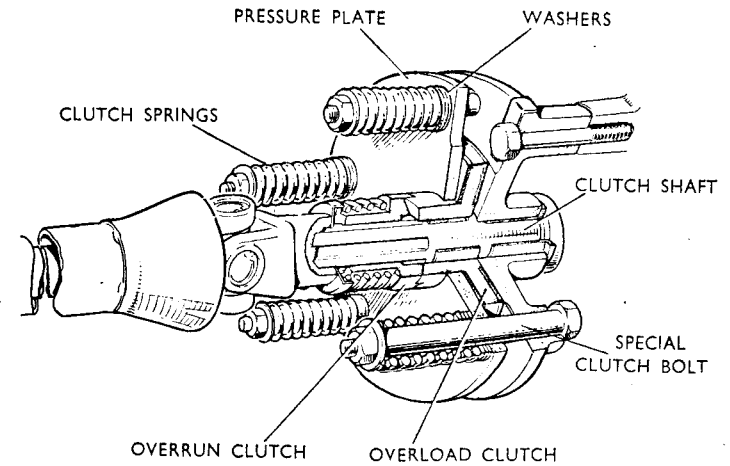

Fig. 50

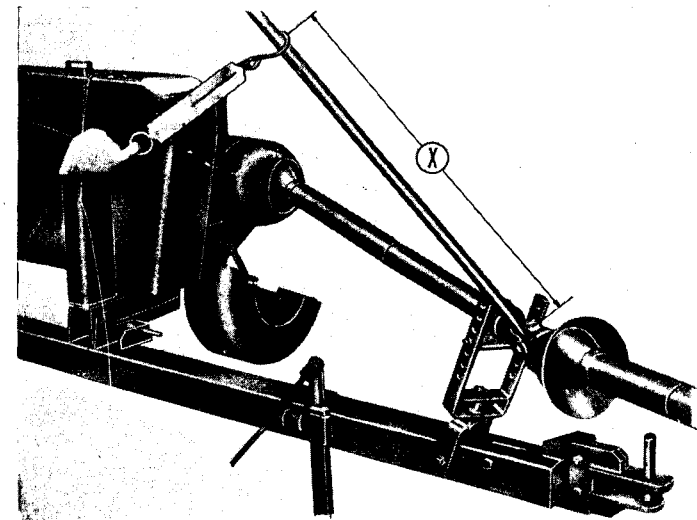

Fig. 51

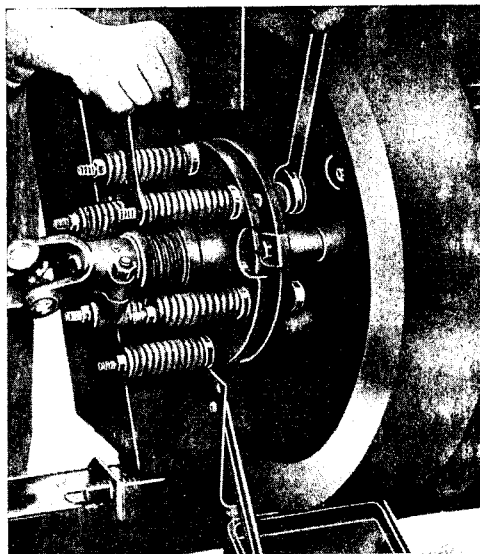

Fig. 52

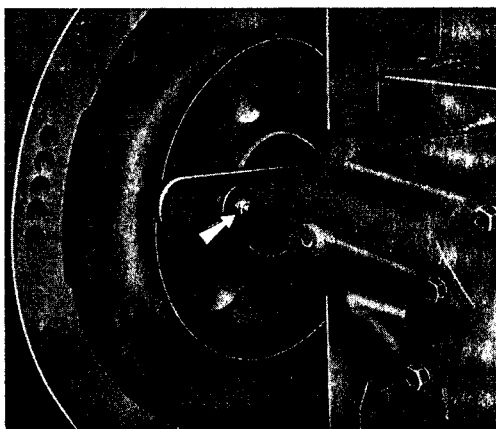

Fig. 53

Readings outwith these figures will necessitate adjustment of the clutch.

To adjust overloading clutch proceed as follows:

- Release flywheel cover clip and expose flywheel.
- Remove bolts securing clutch guard to flywheel cover.
- Slide clutch guard clear of clutch.

**Increase** clutch pressure plate adjustment by **adding** washers between the clutch springs and pressure plate.

**Decrease** clutch pressure plate adjustment by **removing** washers from between the clutch springs and pressure plate.

Add or remove one washer at a time to all pressure springs.

Recheck torque setting as previously described and readjust clutch as necessary.

**NOTE** — Ensure that an equal number of washers are fitted to each spring.

If new clutch linings have been fitted, the clutch torque must be rechecked after a period of service and the clutch readjusted as required.

## II) A flywheel shear bolt

The flywheel is secured to the baler pinion shaft driving lug by a shearbolt.

If any sudden obstruction occurs in the bale chamber, this 5/16" (8 mm) steel bolt shears which allows the flywheel to rotate without power being transmitted to the rest of the machine.

This can occur when the plunger stop comes into operation so that it is necessary to ascertain the reason for the bolt shearing prior to its replacement.

The shearbolt is a high tensile 70 tons sq. in (100 kgm/sq. mm) bolt.

Use specified M-F bolts for this purpose.

Fig. 52 - ADJUSTING THE CLUTCH

Fig. 53 - FLYWHEEL SHEAR BOLT

## SAFETY DEVICES

Special steel shear bolts for replacement are provided in tool box. Check the tightening of the shear bolt.

After replacing a shear bolt, it is recommended that the flywheel be turned by hand to insure the machine runs freely.

**NOTE** — Check flywheel securing set screw at the shaft end (behind overloading clutch).

### III) An over run clutch.

A pawl drive allows the tractor P.T.O. to operate the baler but avoids the tractor P.T.O. shaft being turned by baler momentum when suddenly decreasing engine r.p.m.

This safety device protecting the tractor requires no adjustment.

## PICK UP

A one way clutch on pick up drive avoids the pick up turning in the reverse direction and tines being damaged should the plunger make the baler rotate in reverse direction, when the machine is stopped or turned backwards.

## PACKER FINGERS

Three safety devices are provided :

- 1) A shear bolt C figure 54 secures the packer drive sprocket to gear box shaft. Should packer finger overloading occur, this bolt shears avoiding drive parts being damaged.  
Special spare shear bolts are provided in the tool box.
- 2) Left and right hand packer fingers are spring loaded A fig. 54 which permits them to retract if an excessive amount of hay enters the bale chamber.
- 3) Left hand packer fingers B fig. 54 which enter bale chamber are wooden so as to avoid damaging shear blades if they were in the bale chamber and mistimed in relation to the plunger.

**NOTE** — N° 15 Pick up baler is equipped with double packer fingers  
N° 20 Pick up baler is equipped with triple packer fingers (fig. 54 B) which even the flow of crop to the bale chamber and improve bale shape.

Fig. 54 A    A - SAFETY SPRING    B - WOODEN FINGER    C - SHEAR BOLT  
Fig. 54 B - TRIPLE PACKER FINGERS

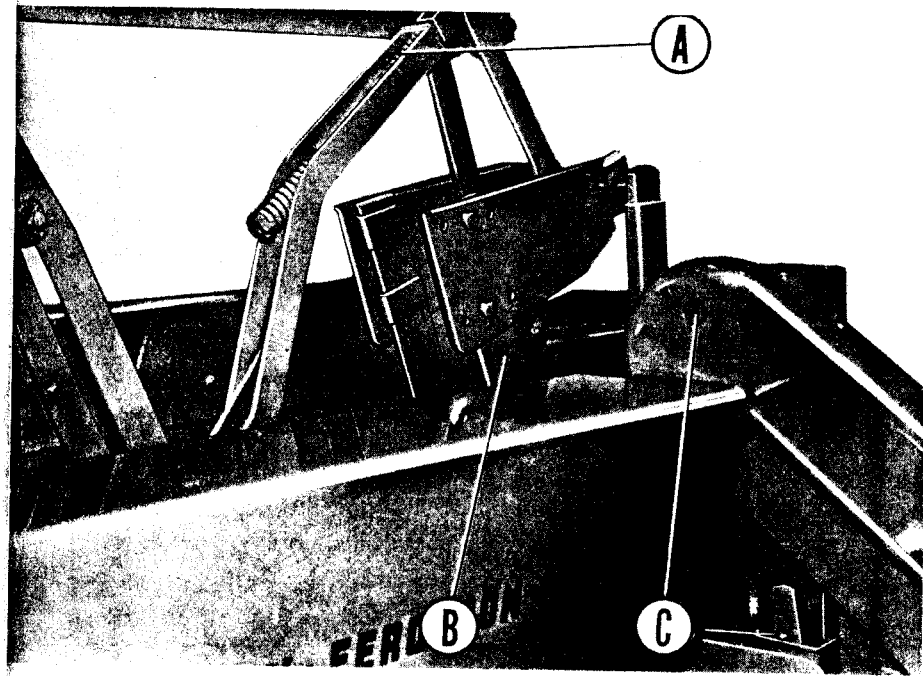

Fig. 54 A

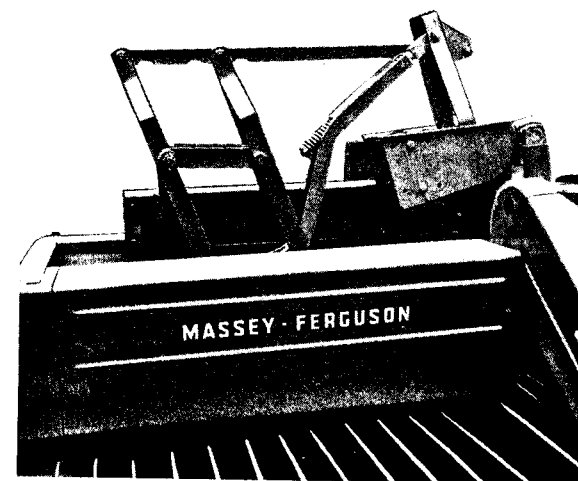

Fig. 54 B

## NEEDLES

Should the needles enter the bale chamber out of time or remain in the bale chamber due to failure of the driving mechanism, a plunger stop prevents the plunger from travelling to the rear of the machine and damaging the needle. When the plunger is stopped in this way, the shear bolt in the flywheel is sheared and the drive to the machine is disengaged.

The safety stop may require to be adjusted. The stop must be fully into the bale chamber when needle tips enter the bale chamber and be withdrawn by the bell crank lever and needle gate as the needles retract.

To adjust the plunger stop proceed as follows:

- 1) Ensure needle timing is correct.
- 2) Position plunger clear of needle slots and plunger stop and remove any hay, straw, etc. which may be in the proximity of the needles and plunger stop.
- 3) Trip the knotter mechanism by turning metering wheel.
- 4) Push needle gate downwards until the needles are about to enter the bale chamber or have entered not more than 1/2" (12.7 mm).
- 5) Check that the plunger stop is then protruding fully into the bale chamber (stop face in a vertical position).
- 6) If the plunger stop is not protruding into the bale chamber, the connecting link must be adjusted by means of the nuts provided (fig. 55) ensure after adjustment that the jam nuts are screwed hard against the adjusting nuts.
- 7) Withdraw needles from bale chamber.
- 8) Rotate flywheel by hand observing needle and stop action.

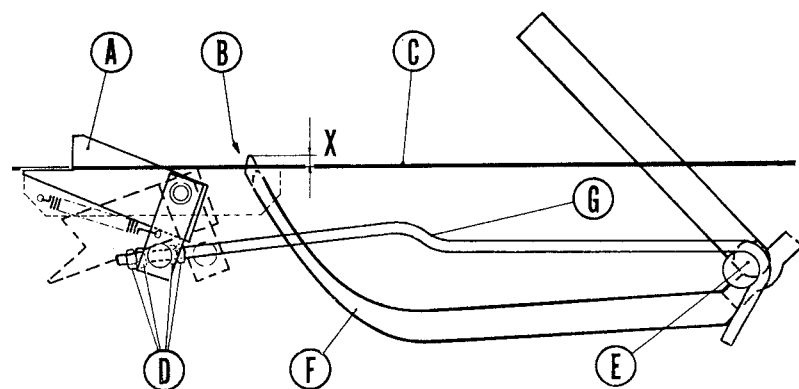

Fig. 55

Fig. 55

- |                            |                      |
|----------------------------|----------------------|
| A - PLUNGER STOP           | D - ADJUSTING NUTS   |
| B - NEEDLE ROLLER          | E - NEEDLE GATE      |
| C - BOTTOM OF BALE CHAMBER | F - NEEDLE           |
| X - 1/2" TOLERANCE         | G - CONNECTING LEVER |



SECTION VII

**MAINTENANCE**

In order to obtain a long life from the baler, it is advised that attention be given to the lubrication table (fig. 56) and that the recommendation given be adhered to.

**DAILY**

| Grease the following nipples:  | Ref | Qty |
|--------------------------------|-----|-----|
| — Connecting rod bearing ..... | 1   | 2   |
| — Packer crank bearing .....   | 2   | 1   |
| — Twine finger spindle .....   | 3   | 2   |
| — Needle drive rod .....       | 4   | 1   |
| — Chain tension sprocket ..... | 9   | 1   |

**WEEKLY**

|                                       |   |   |            |
|---------------------------------------|---|---|------------|
| — Draw bar roller .....               | 5 | 1 |            |
| — Flywheel (*) .....                  | 6 | 1 |            |
| — P.T.O. shaft support bracket .....  | 7 | 1 | (20 baler) |
| — P.T.O. shaft universal joints ..... | 8 | 3 | (20 baler) |
|                                       |   | 2 | (15 baler) |

(\*) It is important to carefully grease this nipple to obtain proper declutching if the safety bolt shears.

Fig. 56

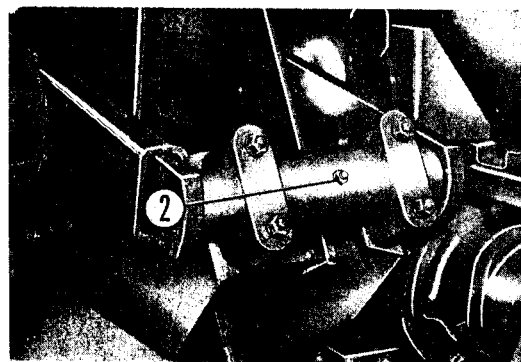
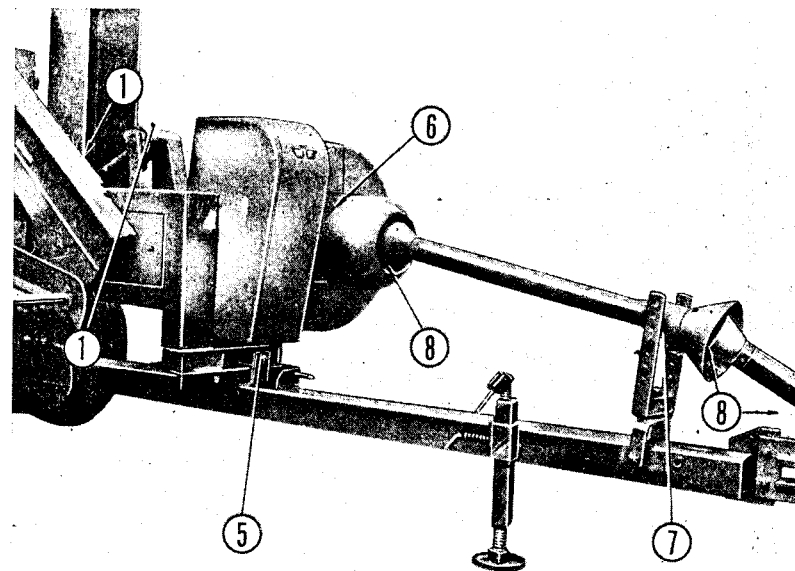

Fig. 57

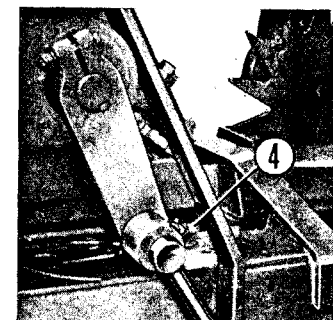

Fig. 56 A

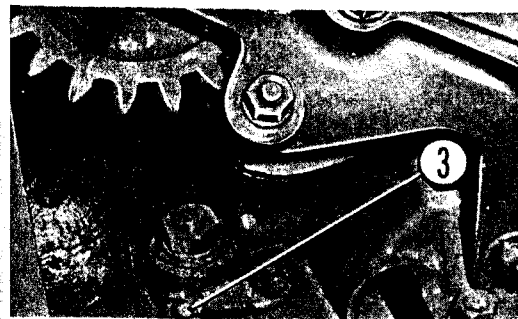

Fig. 58

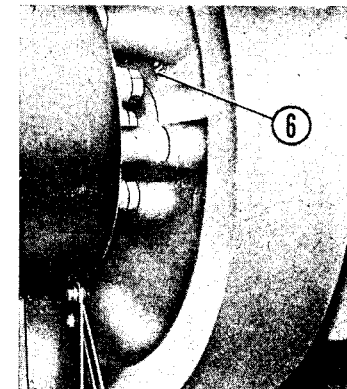

Fig. 59

**YEARLY OR EACH 20 000 BALES**

- Drain main gear box oil. Refill with SAE 90 EP hypoid oil to the level plug. No other type of oil must be used.
- Check packer gear housing grease level. Repack if necessary with fresh grease. The packer gear box should be one quarter filled with soft chassis grease.
- Check right hand packer bearing housing grease level. Remove cover on this bearing housing to examine the grease level, which should be approximately level with the shaft. Soft chassis grease should be added annually to maintain the correct level.
- Pick up drive clutch.  
This clutch is packed with graphited grease at the factory which normally lasts the life of the machine. It is nevertheless advantageous to repack when the machine is overhauled or annually.
- Hub bearings.

Pack the hub annually with long fibre roller bearing grease.

This can be done by removing the hub cap, packing both cap and the area around the cap. When the fully charged cap is put into position, it forces grease through the outer bearing into the hub chamber, and so reaches the inner bearing.

Repeat this operation until the cap becomes difficult to replace, indicating that the hub is fully charged.

**OIL IMPREGNATED METAL BEARING**

Various bearings on the machine are made from oil impregnated metal which normally lasts the life of the machine but it is nevertheless advantageous to add light machine oil to the bearings annually, or each 20 000 bales.

**NOTE** — Do not lubricate knotter mechanism as grease may retain dust and produce an abrasive paste which quickens parts wear.

**MAIN GEARBOX**

With continuous use, and in particular in hot weather conditions, the main gearbox may reach a temperature considerably higher than is usually obtained with ordinary spiral bevel gears-particularly in the running-in period.

It is essential to maintain the full oil level with the correct type and grade of oil for these hypoid gears from an approved manufacturer. It is important to renew the oil after the first 30 hours work.

Fig. 60 - A - FILLER PLUG B - DRAIN BOLT      Fig. 62 - PACKER BEARING HOUSING  
Fig. 61 - PACKER GEAR HOUSING      Fig. 63 - KNOTTER DRIVE CHAIN ADJUSTMENT

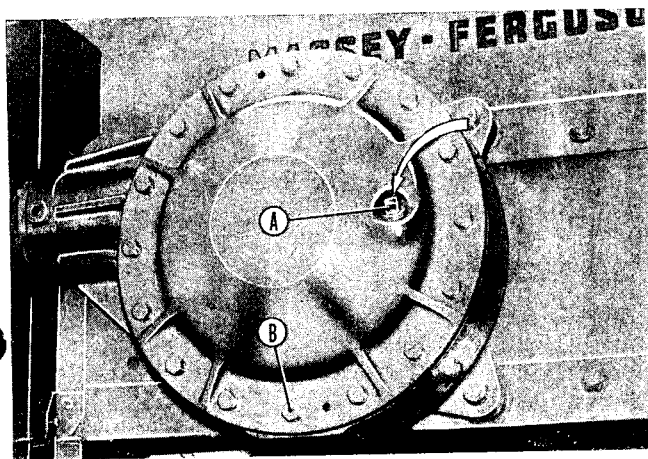

Fig. 60

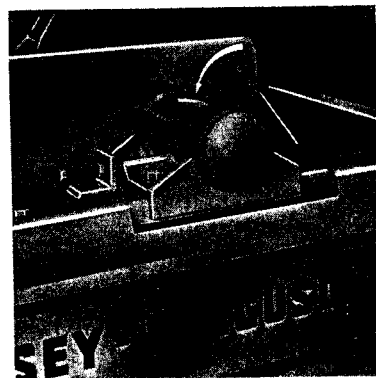

Fig. 61

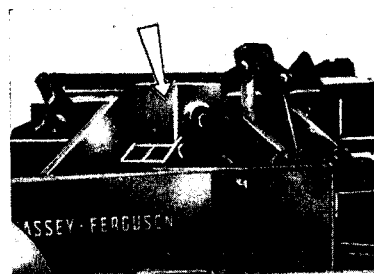

Fig. 62

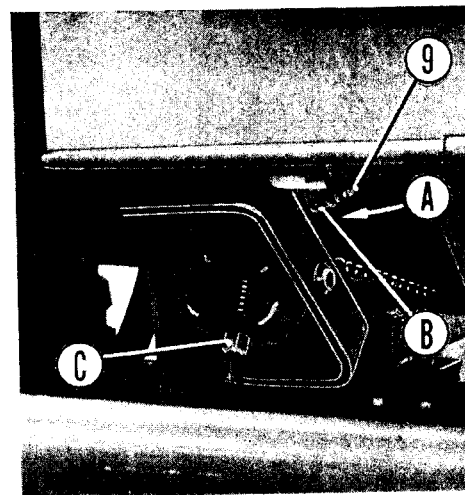

Fig. 63

**CHAINS**

**Chain tension**

It is important to keep the chains at the correct tension. Slackness causes chain snatch with consequent damage whilst over-tightening will accelerate wear and breakage. As an approximate guide the non-driving side of the chains when gripped between fore-finger and thumb at the centre of the span should move about 3/4" when a force of 5 lbs is applied.

Right hand packer crank drive chain adjustment is made by moving the packer crank bearing housing by means of the adjusting bolt after slackening lock nut and the four securing nuts (fig. 61).

Knotter drive chain adjustment is made by screwing the adjusting bolt C after slackening securing bolt A and setscrew B (fig. 63).

**Chain lubrication**

It is not recommended to lubricate dirty chains as oil cannot penetrate between rollers and pins and retains dust which forms an abrasive paste quickening chain wear.

To lubricate chains correctly, it is necessary to remove and clean carefully in kerosene then to boil them for half an hour in transmission oil or tallow, to allow the oil to penetrate. Then wipe chains with rag before replacing.

This operation is to be carried out before storage.

**TYRES**

Check pressure periodically and set if necessary at:

|             |                           |                |
|-------------|---------------------------|----------------|
| — R.H. Tyre | 500 × 16                  | 28.4 lbs/sq in |
| — L.H. Tyre | 650 × 16 (standard)       | 40 lbs/sq in   |
| — L.H. Tyre | 900 × 16 (as accessories) | 40 lbs/sq in   |

**RUNNING-IN**

It is recommended to carefully carry out maintenance operations during the first few days work.

Main drive gear box oil should be renewed after first 30 hours work.

Plunger guide rails and shear knife clearances should be checked during the first few days work and any increase of clearance caused by "running in" corrected as shown on pages 26-29.

**WINTER STORAGE**

Before storage it is advisable to have a general overhaul of the baler and to carry out maintenance which will keep the baler in good condition and ready for the next season.

- Carefully clean the inside and the outside of the baler to remove dust, straw, old grease, etc.
- Grease nipples and coat plunger guide angles with new grease then turn baler slowly to distribute grease evenly.
- Grease inside of the bale chamber, lower part of the pick up gathering shields and all the parts where paint has been removed by straw friction.
- Grease bill hooks and protect the knotter with a waterproof cover.
- Slacken off the tension on all springs and place pick up in transport position.
- Remove all chains, clean and store in a bath of oil.
- Refill main drive gear box oil, and check grease level in packer gear box and in packer housing.
- Jack up the machine and support on blocks ensuring that the tyres are clear of the ground.

## SECTION VIII

### **ACCESSORIES**

#### **TRAILER HITCH**

Where trailers are used it is necessary to use the correct hitch which is fitted to the baler in such a manner as to relieve any unnecessary stress on the bale chamber. This hitch is supplied as optional equipment designed for use with a four wheel trailer and provision for fitting is made on the rear part of the machine.

#### **SPECIAL HITCH FOR SLEDGE**

A special hitch (fig. 64) allows a sledge to be drawn by the baler. Bales drop on the sledge and are unloaded at regular intervals thus permitting them to be picked up more conveniently.

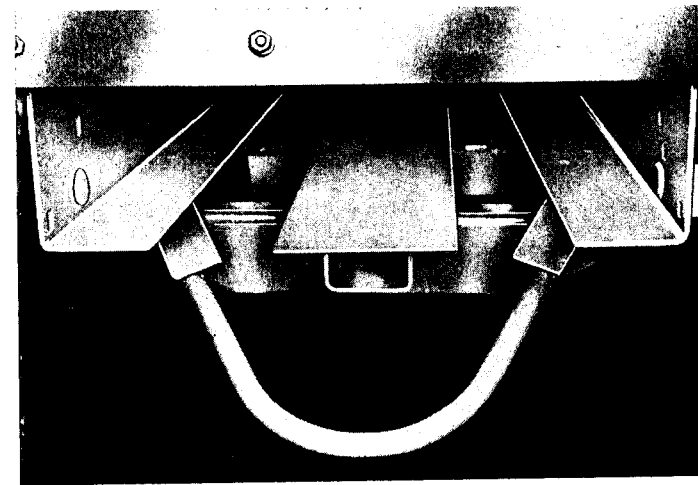

Fig. 64

**OPERATOR  
PARTS  
LIST**

ENSEMBLE DE TIMON  
DRAWBAR

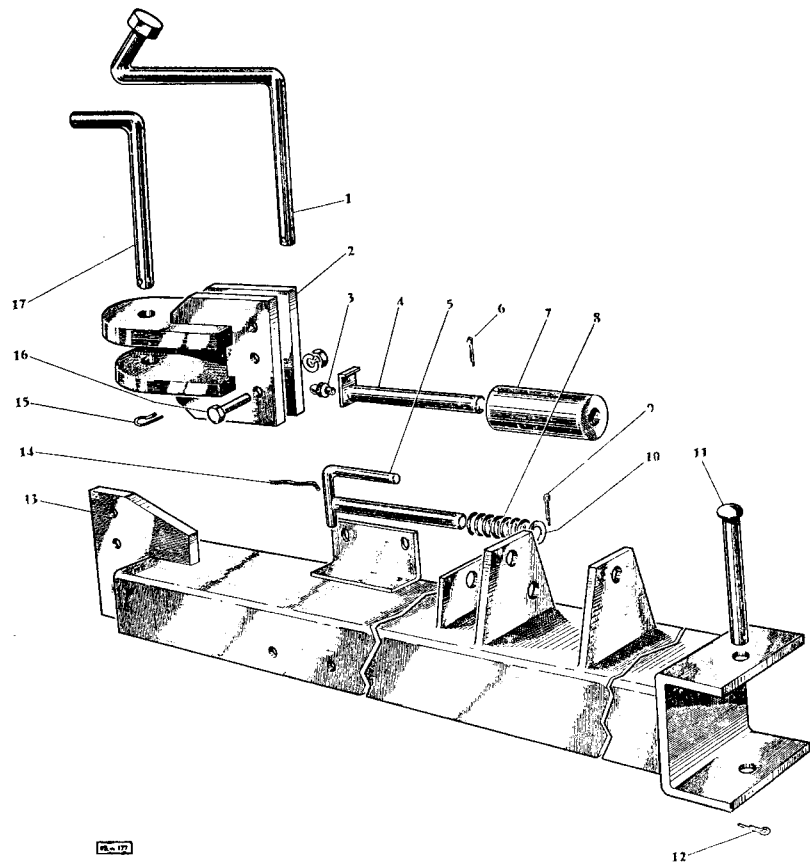

Fig. 1

CRIC  
JACK-ASSEMBLY  
A partir du N° 6 525 (15-8)  
From No. 63 163 (20-8)

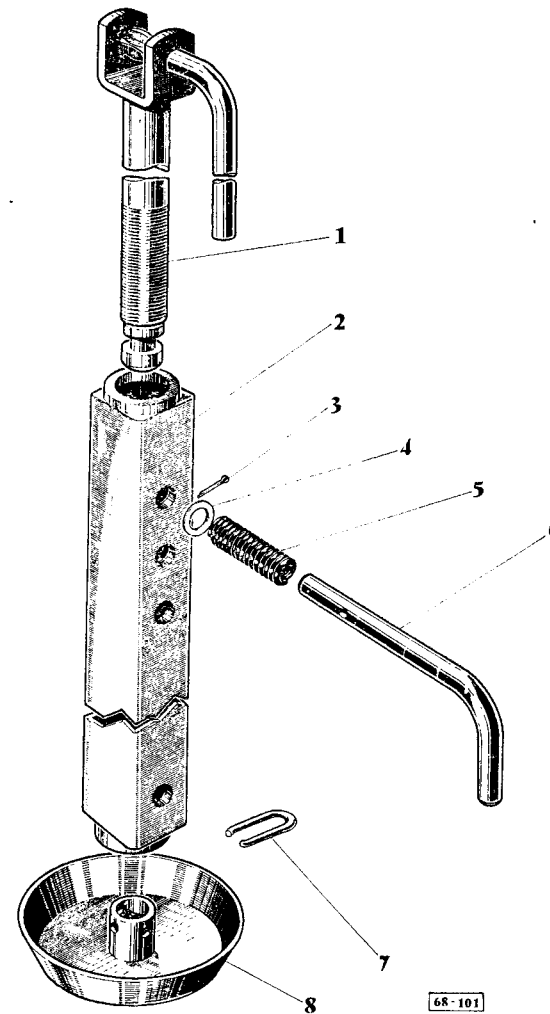
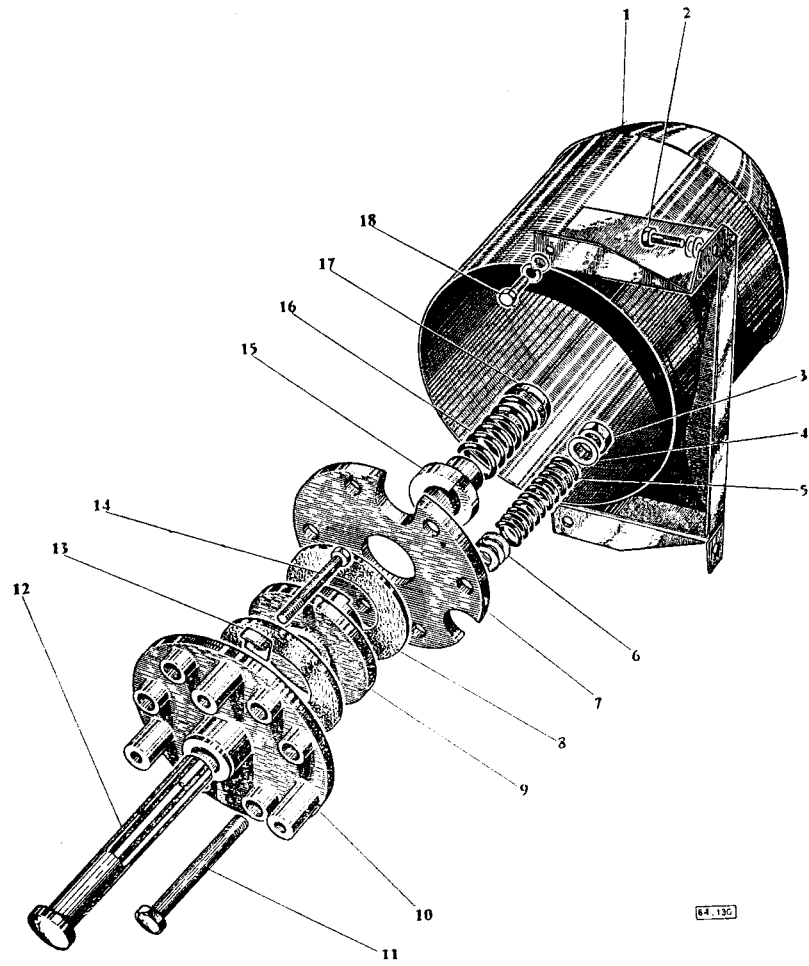

Fig. 2

EMBAYAGE  
CLUTCH



64-130

Fig. 3

ARBRE DE PRISE DE FORCE - SUPPORTS (PRESSE 20-8)  
P.T.O. AND SUPPORTS (20-8 BALERS)

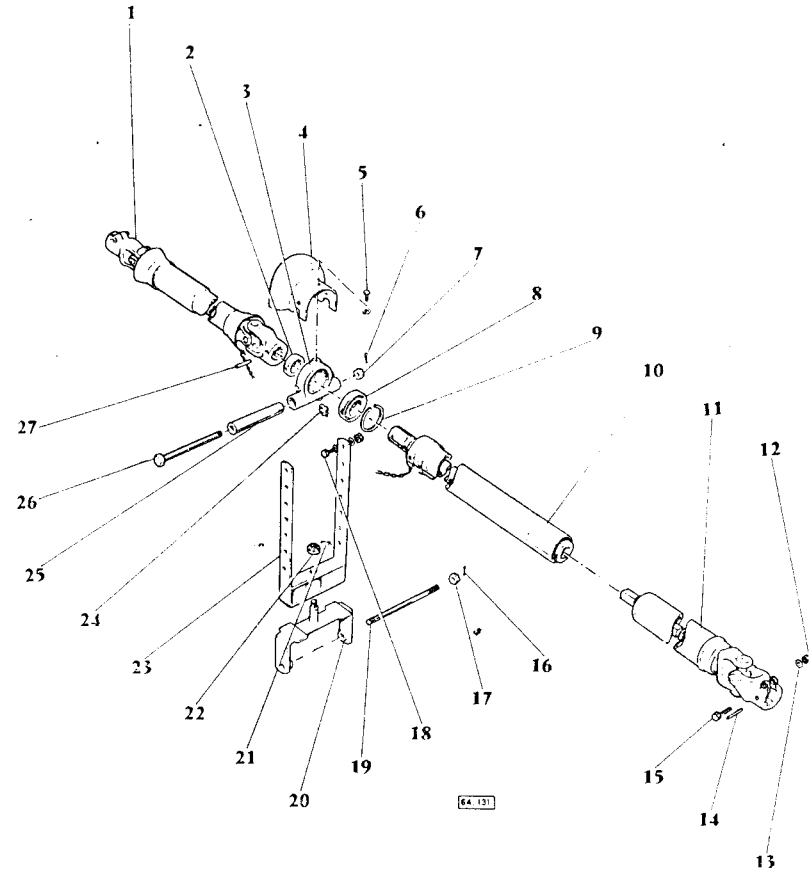

64-131

Fig. 4

ARBRE DE PRISE DE FORCE (PRESSE 15-8)  
SHAFT P.T.O. (15-8 BALERS)

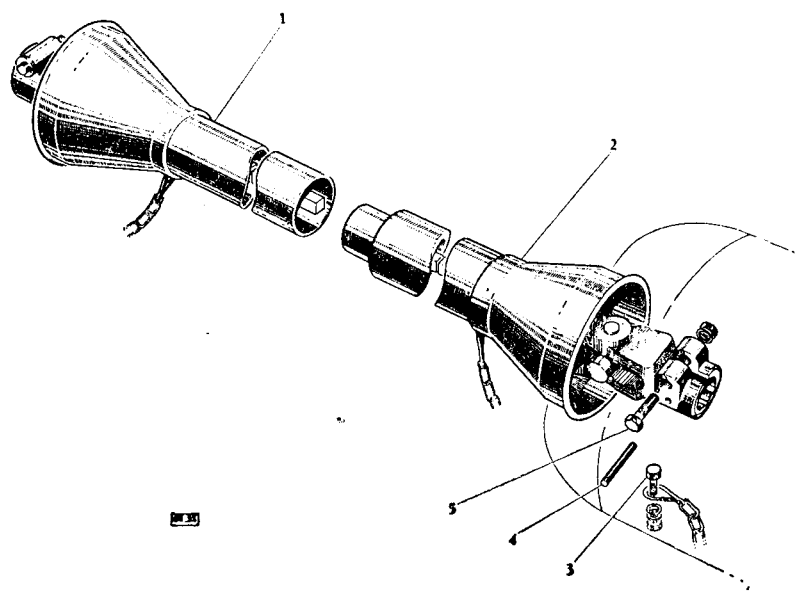

Fig. 5

ARBRE DE PRISE DE FORCE 20-8 (Détail)  
P.T.O. 20-8 (Détail)  
B.R.D. HARDY SPICER

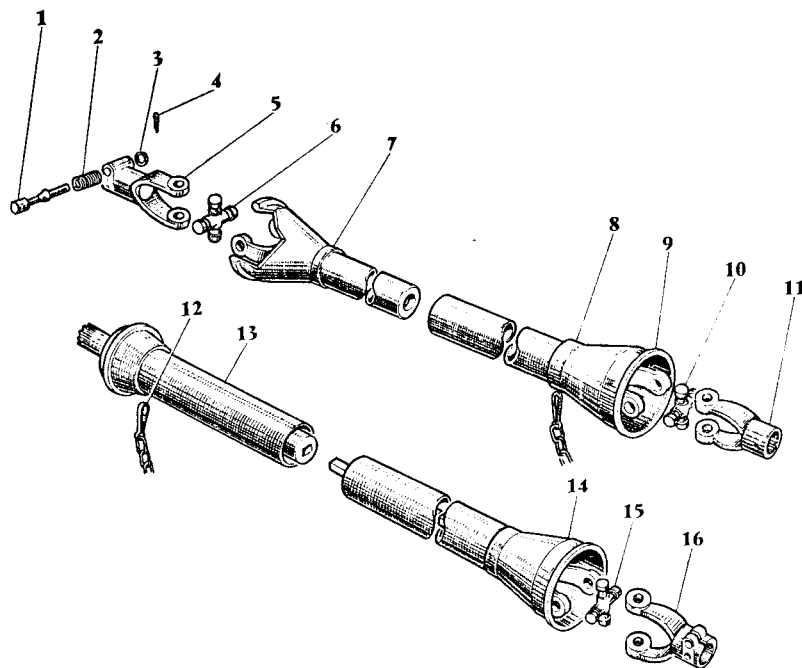

Fig. 6



ARBRE DE PRISE DE FORCE 20-8 (Détail)  
 P.T.O. 20-8 (Detail)  
 GLAENZER WALTERSCHEID

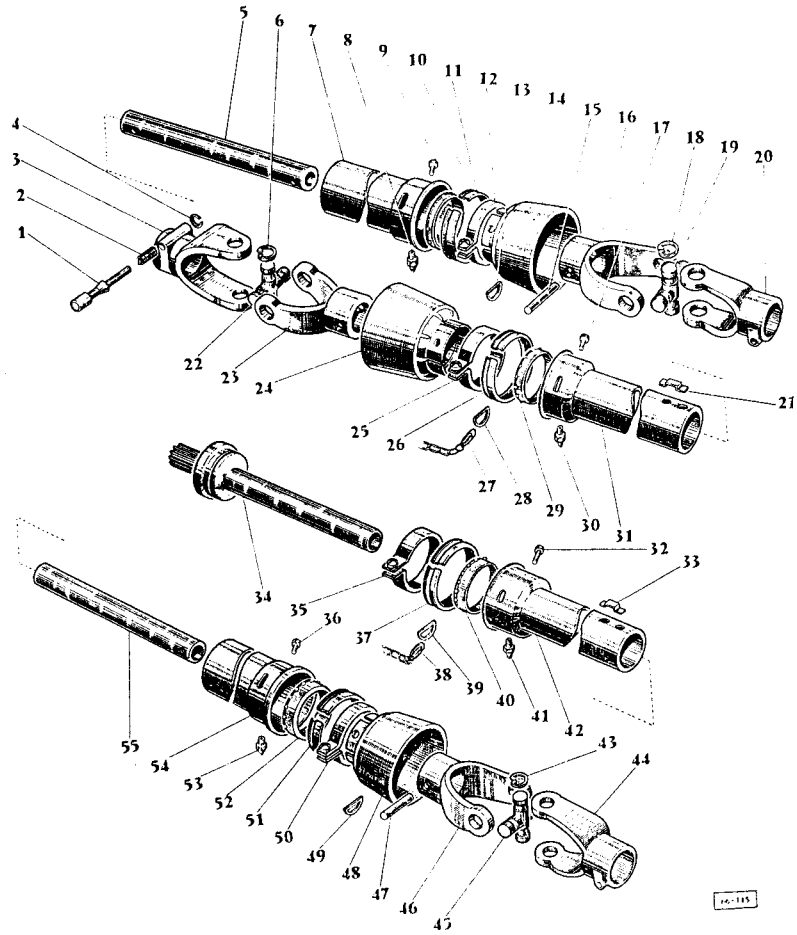

Fig. 7

ARBRE DE PRISE DE FORCE 15-8 (Détail)  
 P.T.O. 15-8 (Detail)  
 B.R.D.

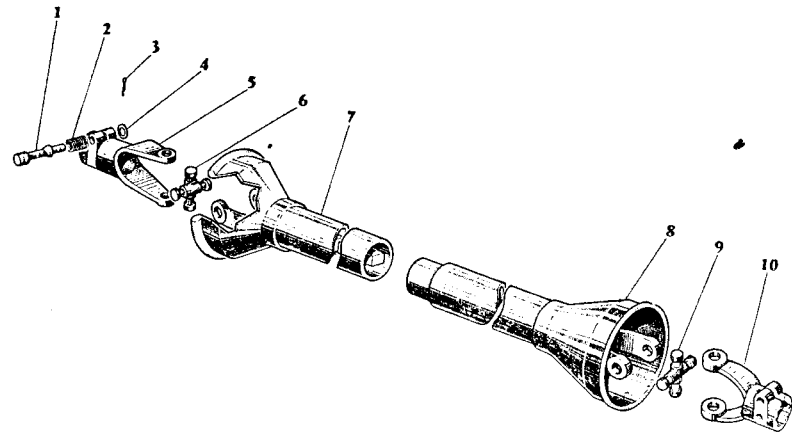

Fig. 8

ARBRE DE PRISE DE FORCE 15-8 (Détail)  
 P.T.O. 15-8 (Detail)  
 GLAENZER WALTERSCHEID

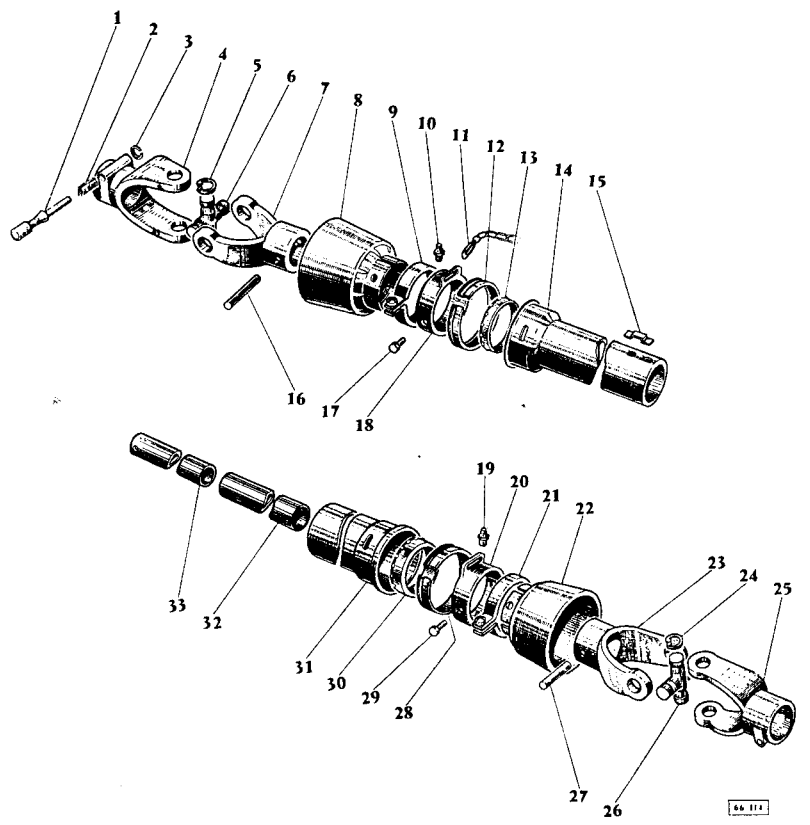
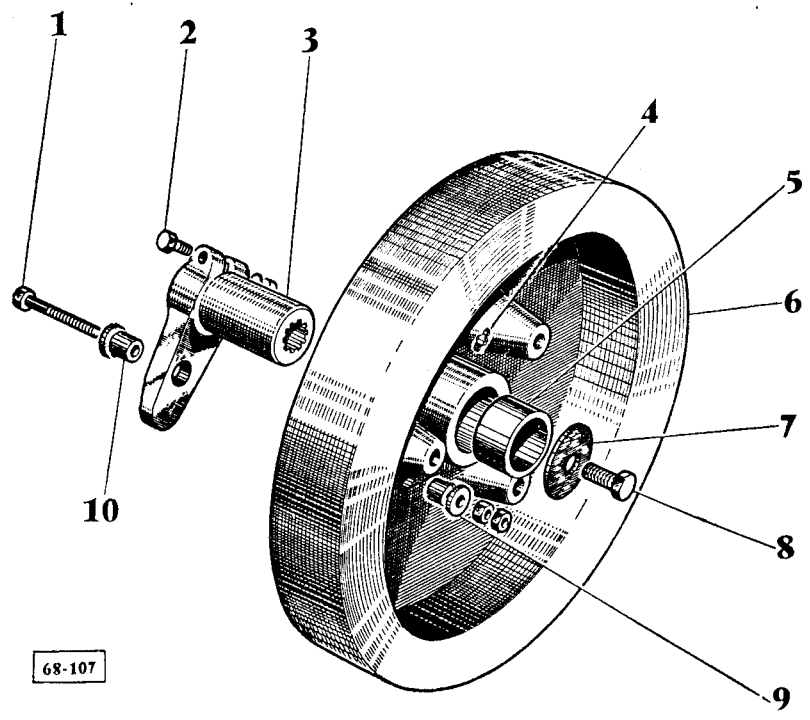

Fig. 9

VOLANT  
 FLYWHEEL



68-107

Fig. 10

GARANT DE VOLANT  
FLYWHEEL-SHIELD

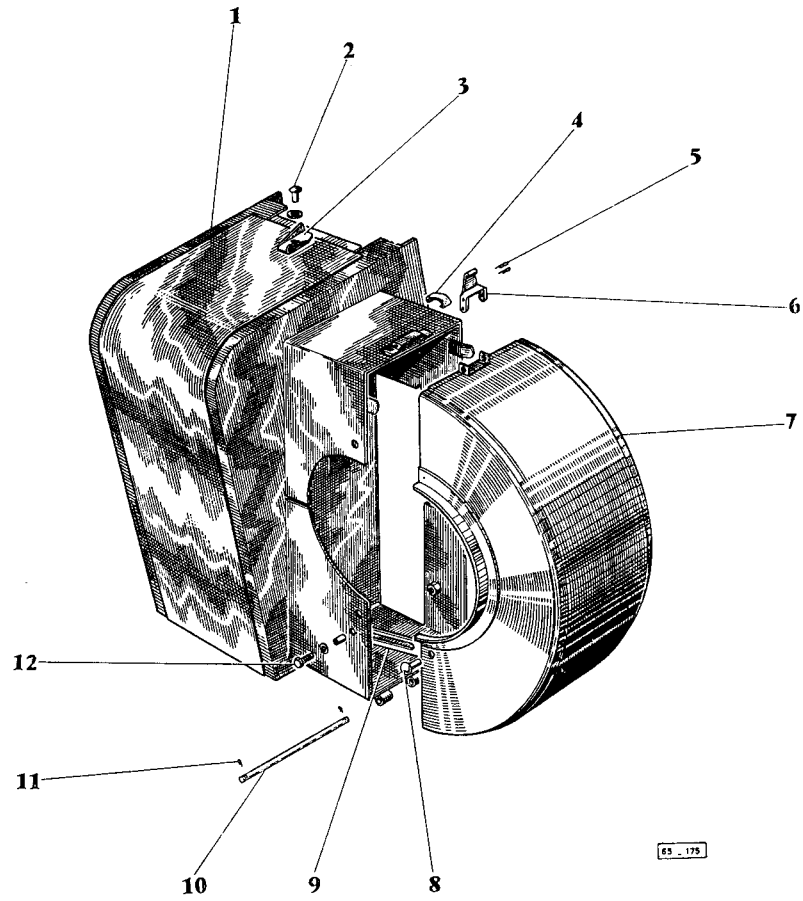

Fig. 11

BOITE D'ENGRENAGE  
HOUSING-GEARS

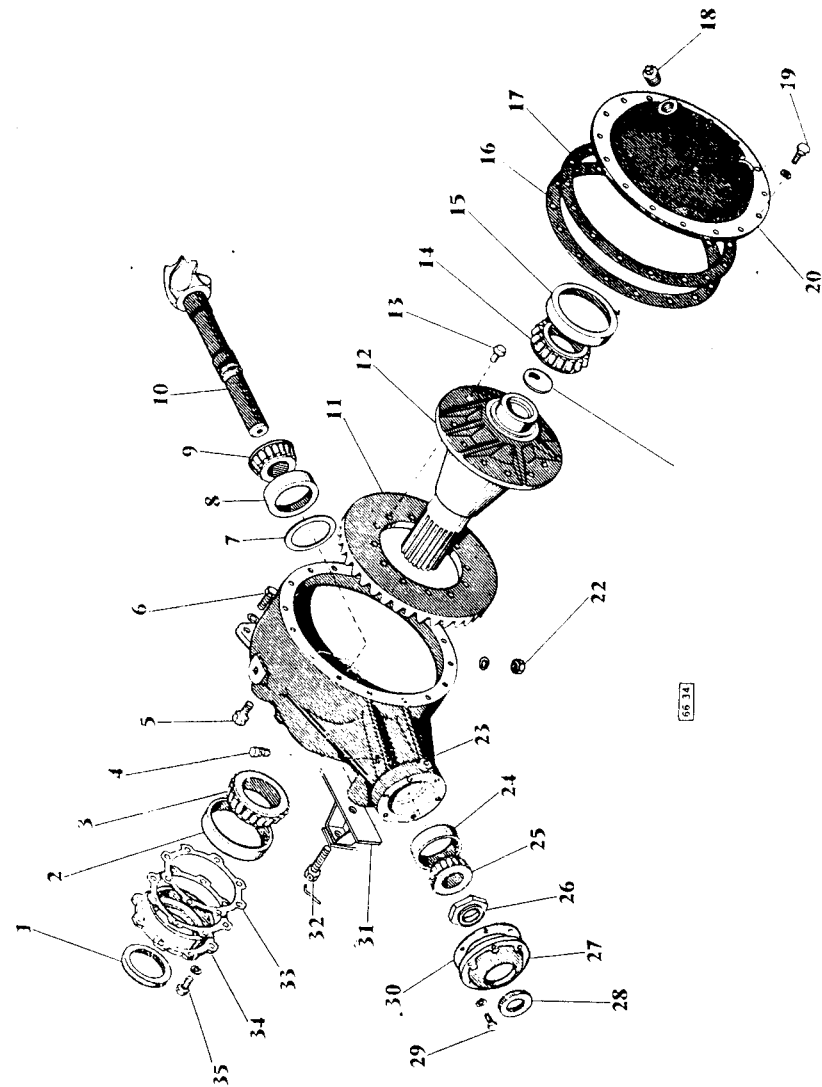

Fig. 12

VILEBREQUIN DE COMMANDE - PISTON - PALIER DE BIELLE  
 PLUNGER-DRIVE-CRANK AND CONNECTING-ROD-BEARING

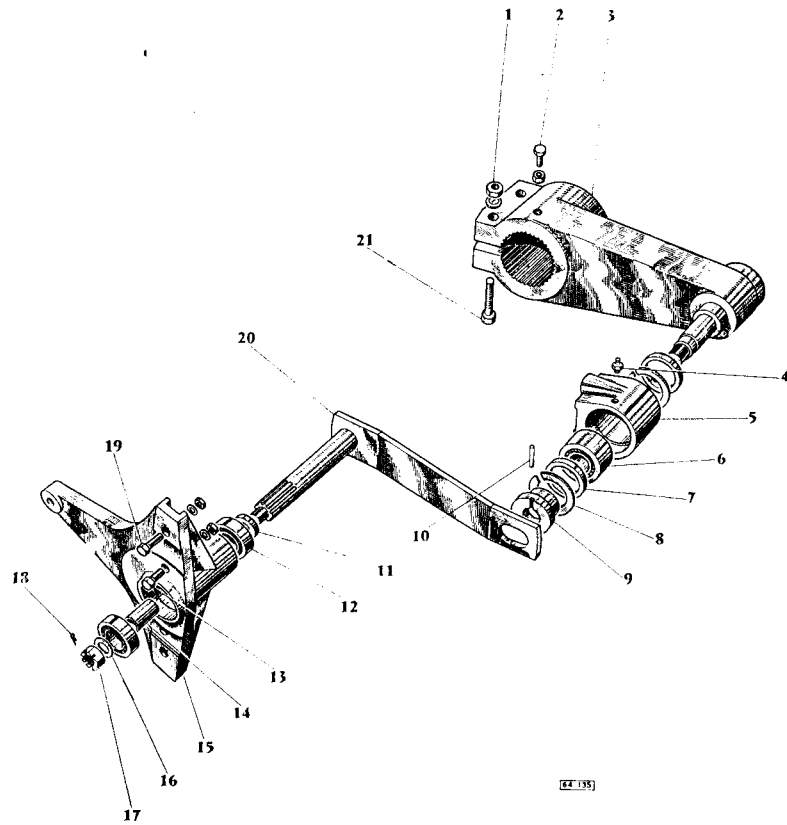

Fig. 13

PISTON ET BIELLE  
 PLUNGER AND CONNECTING ROD  
 A = Patin - Shoe  
 B = Galet - Roller  
 → 7 500 (15-8) - 68 000 (20-8)

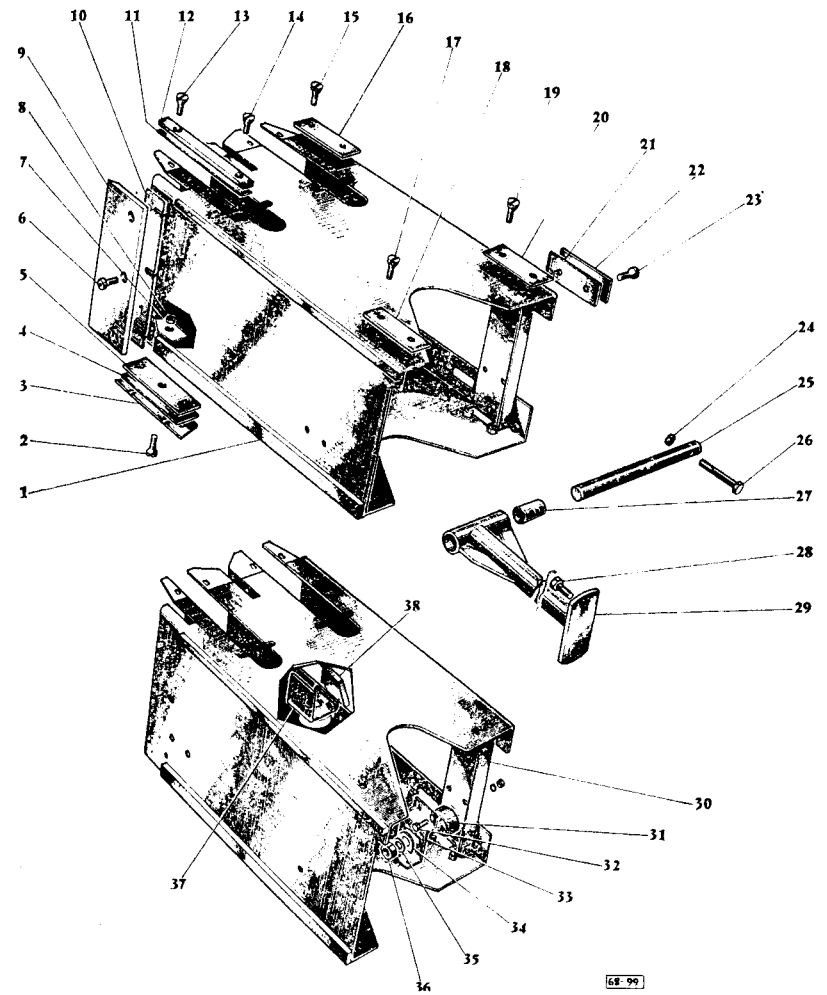

Fig. 14

PISTON ET BIELLE (3 GALETS)  
 PLUNGER AND CONNECTING ROD (3 ROLLERS)  
 N° 7 501 (15-8) - 63 001 (20-8) →

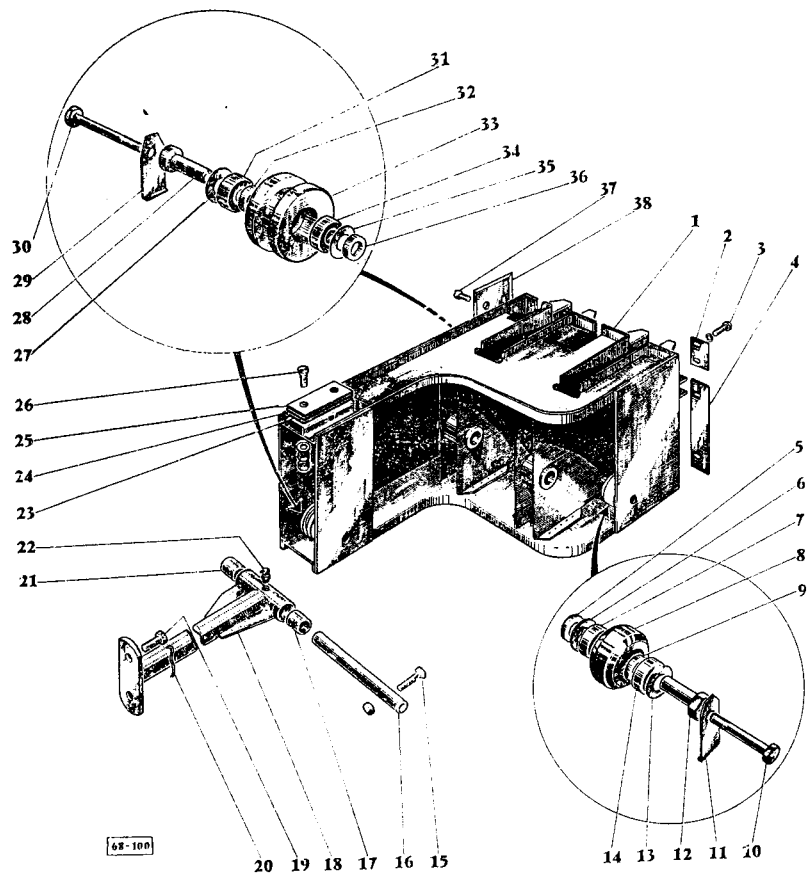

Fig. 15

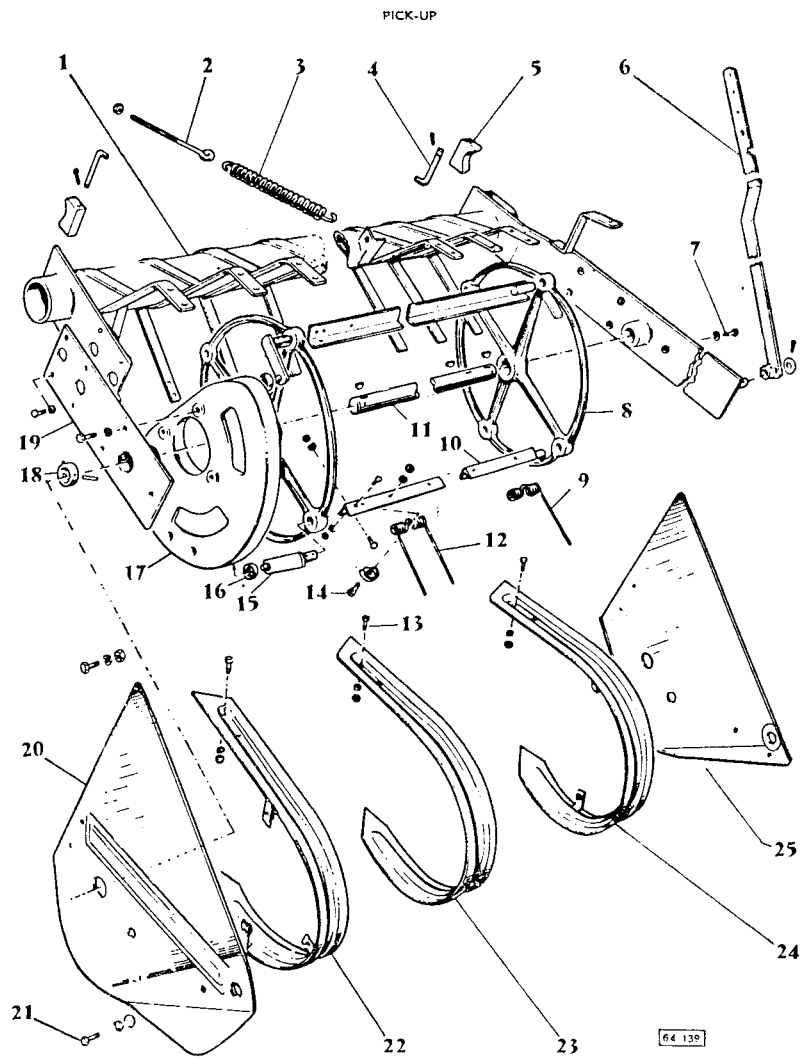

Fig. 16

COMMANDE DE PICK-UP  
PICK-UP DRIVE

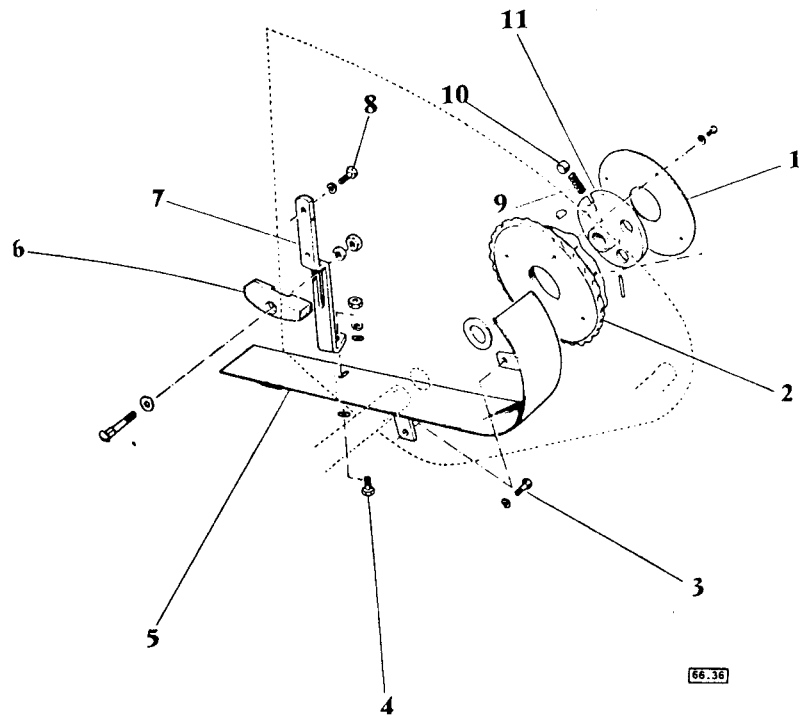

Fig. 17

GUIDE-PAILLE  
CROP-GUIDE

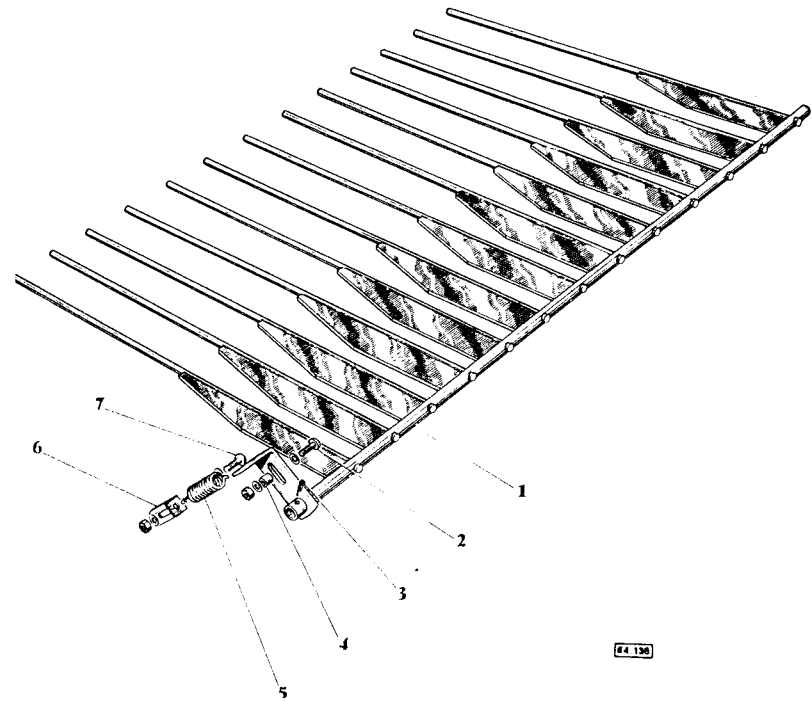
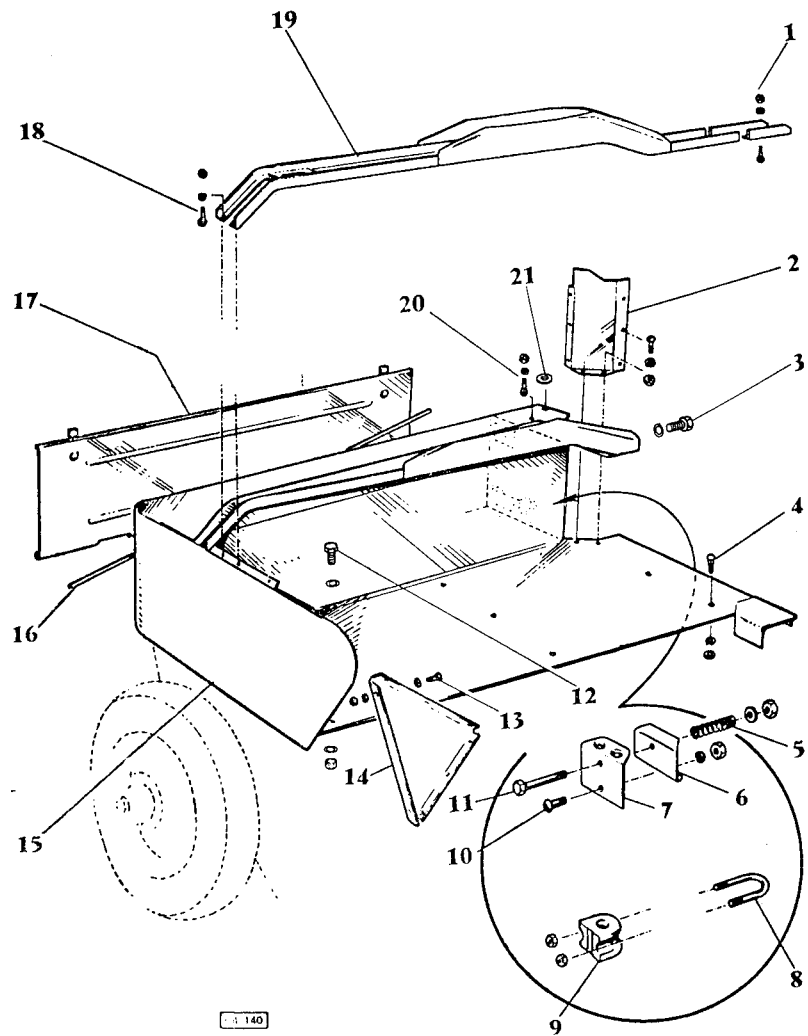

Fig. 18

CARTER ET GUIDE D'ALIMENTATION, BOITE A FICELLE  
 FEED AND TWINE HOUSING, PACKER GUIDE



64-140

Fig. 19

COUVERCLES ET GARANTS DU CARTER D'ALIMENTATION  
 COVERS AND GUARDS OF FEEDING-HOUSING

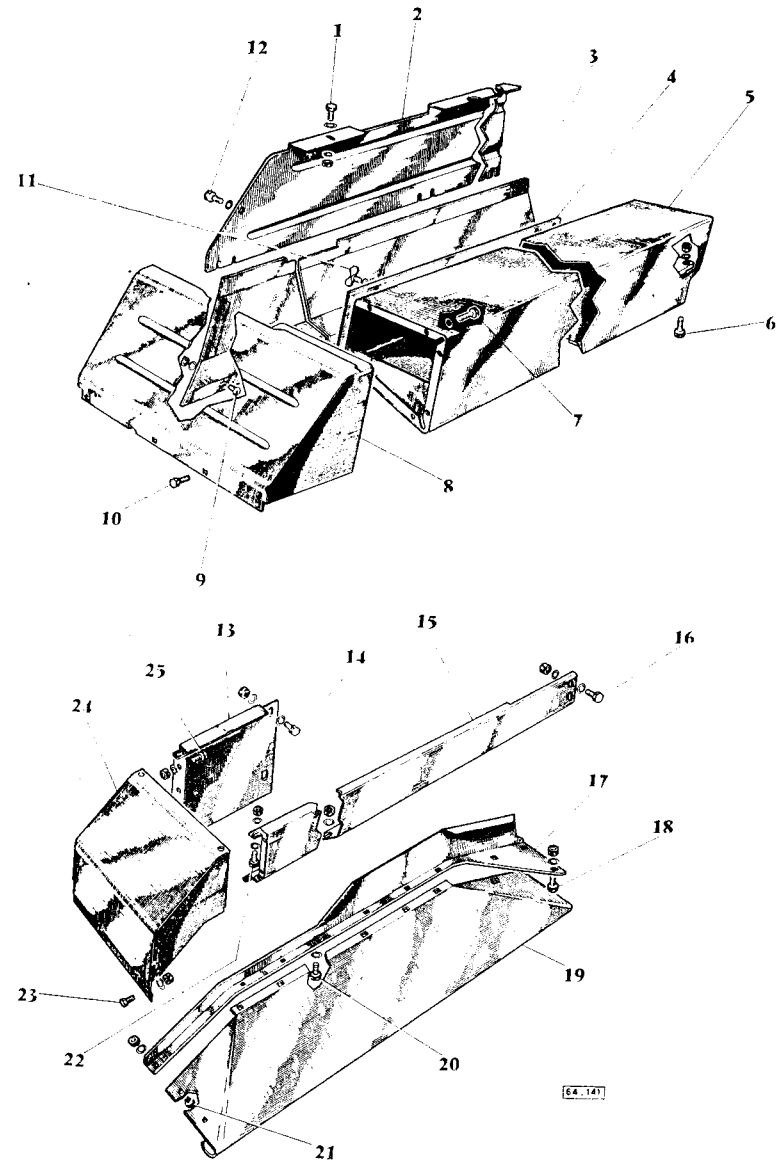

64-147

Fig. 20

BOITIER DE COMMANDE D'ALIMENTATION  
PACKER-DRIVE-GEAR BOX

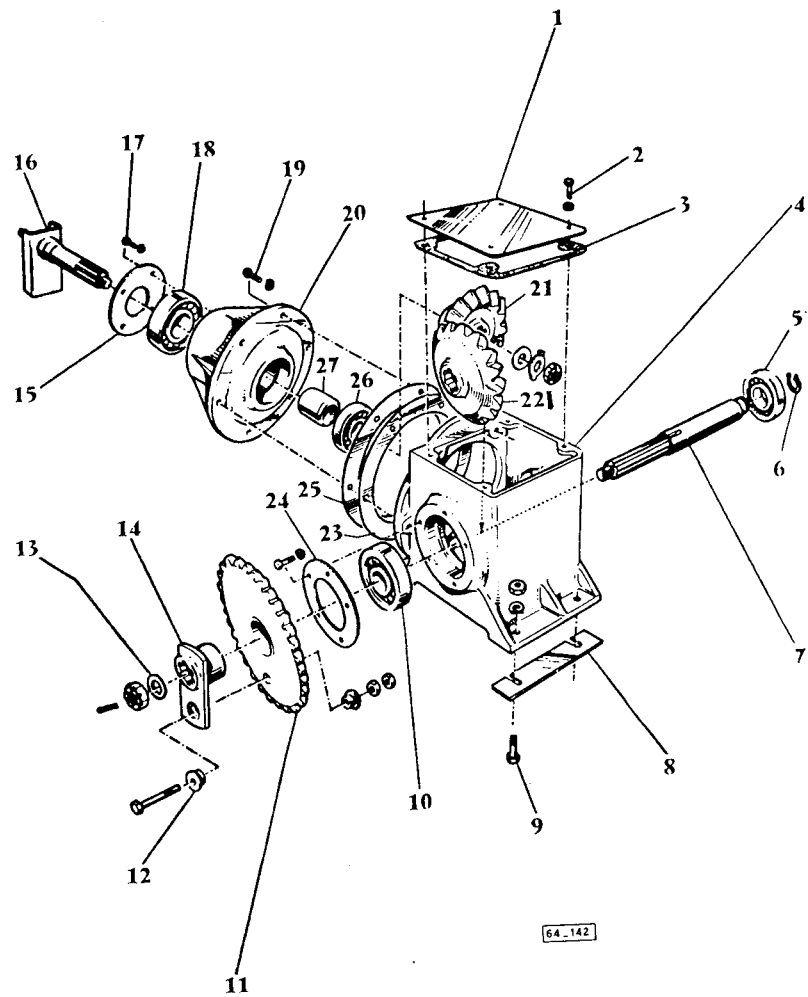

Fig 21

VILEBREQUIN D'ALIMENTATION - PIGNONS - CARTER DE CHAINE  
PACKERS CRANKS - SPROCKET AND CHAIN CASE

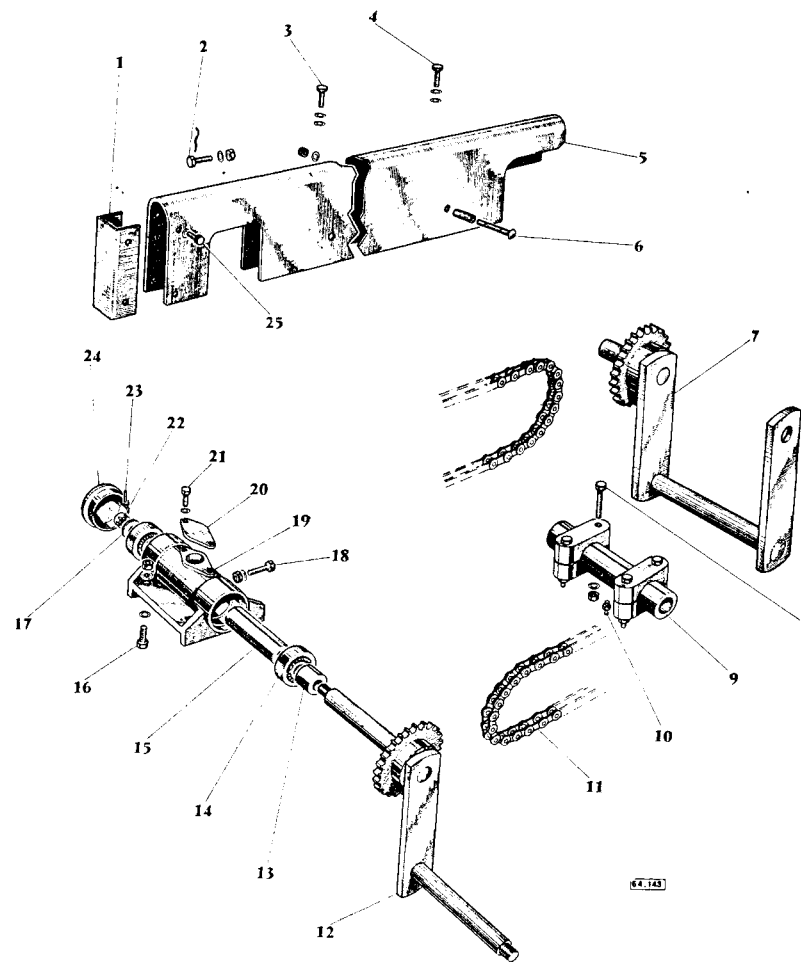
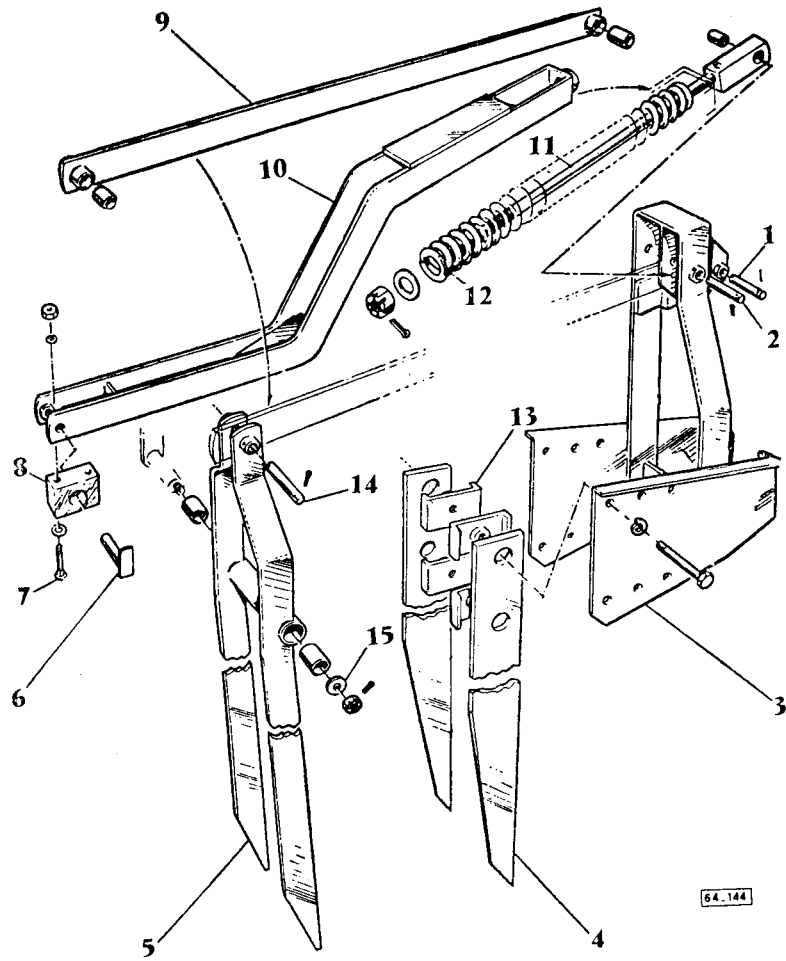

Fig. 22



FOURCHE D'ALIMENTATION, TIGE DE COMPRESSION  
PACKER FORKS, COMPRESSION ROD



64-144

Fig. 23

AMENEUR TRIPLE  
TRIPLE PACKER

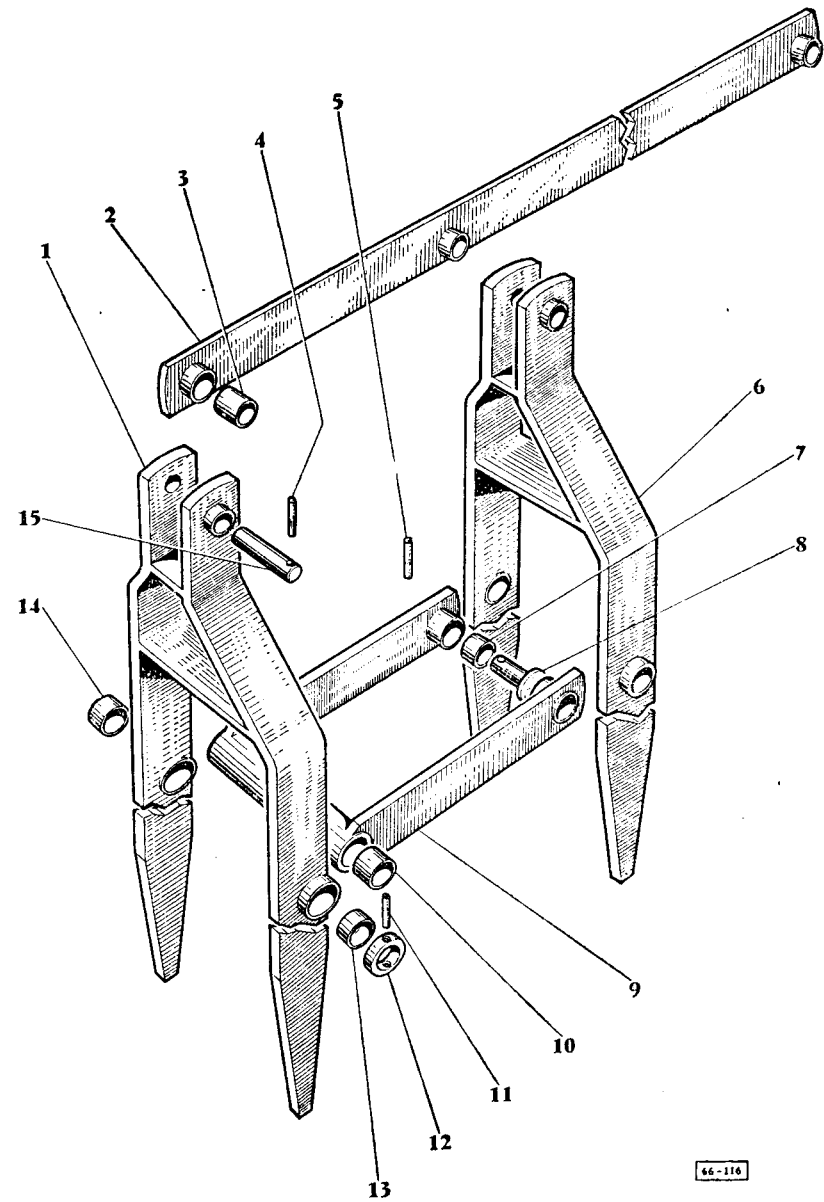

66-116

Fig. 24

SUPPORT ARRIÈRE DE VILEBREQUIN D'ALIMENTATION  
 REAR PACKER CRANCK SUPPORT

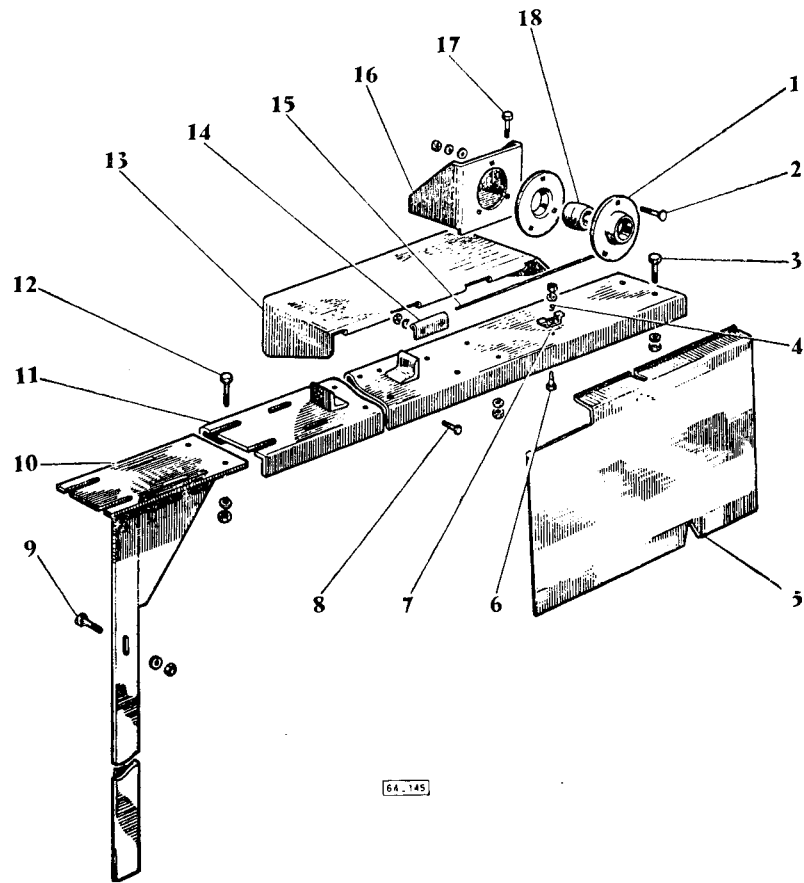

64-145

Fig. 25

CANAL DE PRESSE - GARANTS - LONGERONS - CLIQUETS - LAME DE CISAILLEMENT  
 BALE CHAMBER AND SHIELDS - RUNNER - STOP DOG AND SHEAR BLADE

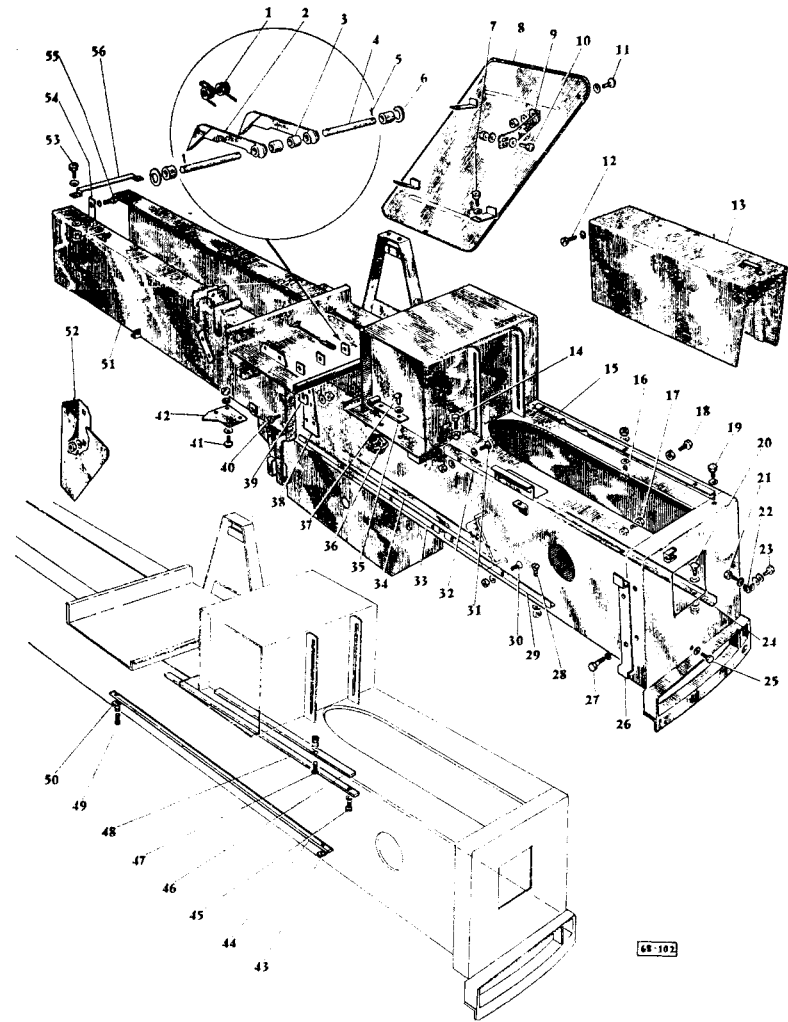

64-102

Fig. 26

ESSIEU - SUPPORT  
MAIN AXLE, CHANNEL AND SUPPORT

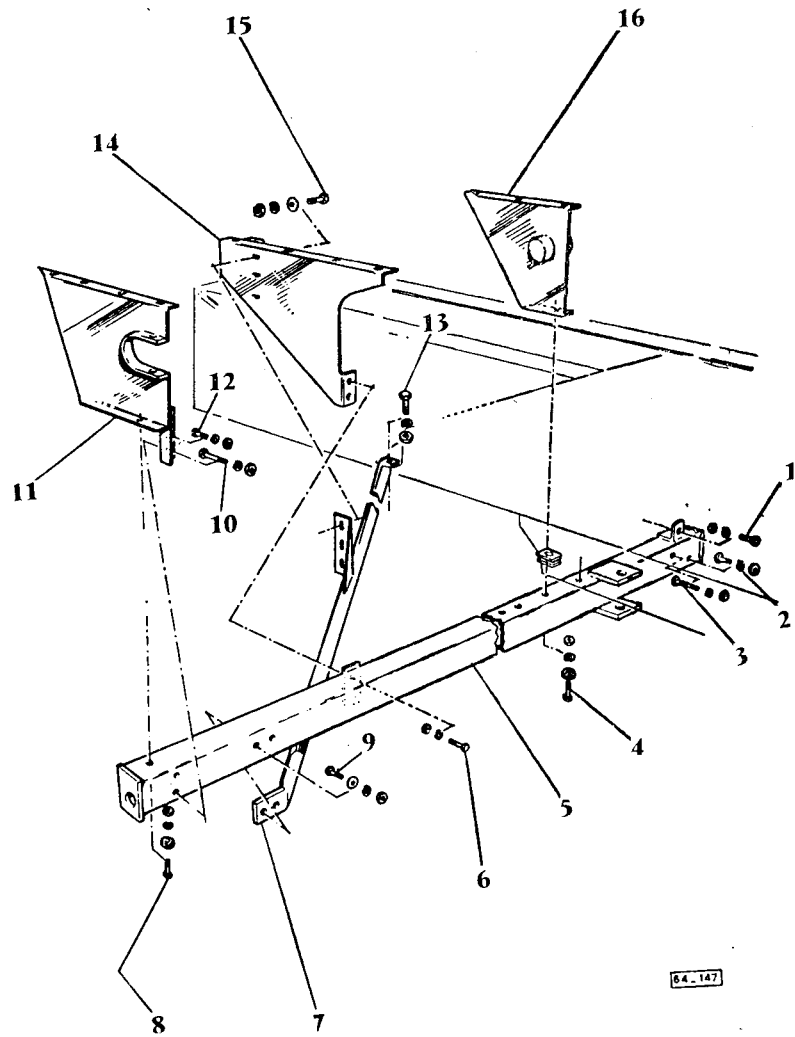

64-147

Fig. 27

ESSIEU AUXILIAIRE  
AUXILIARY AXLE

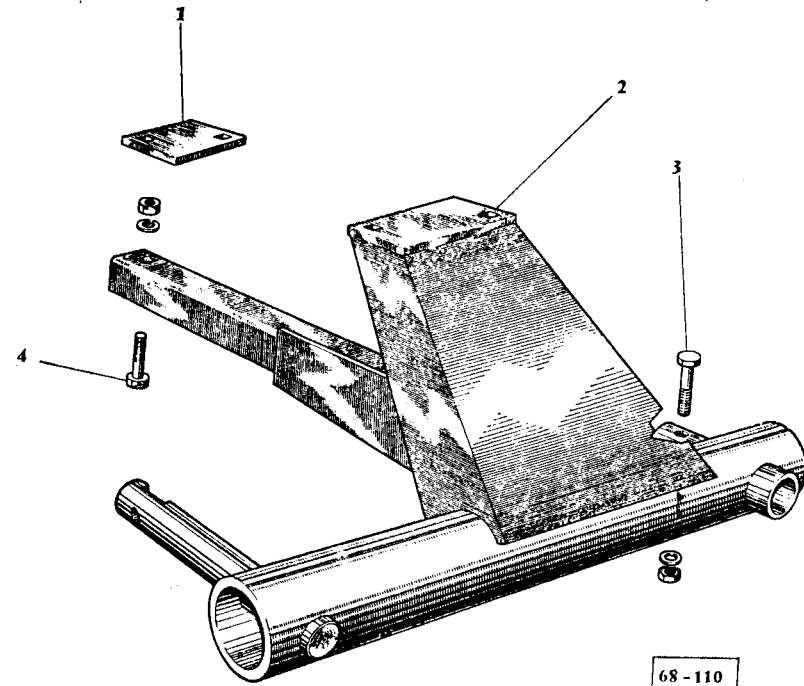

68-110

Fig. 28

FUSÉES ET ROUES  
AXLES AND WHEELS

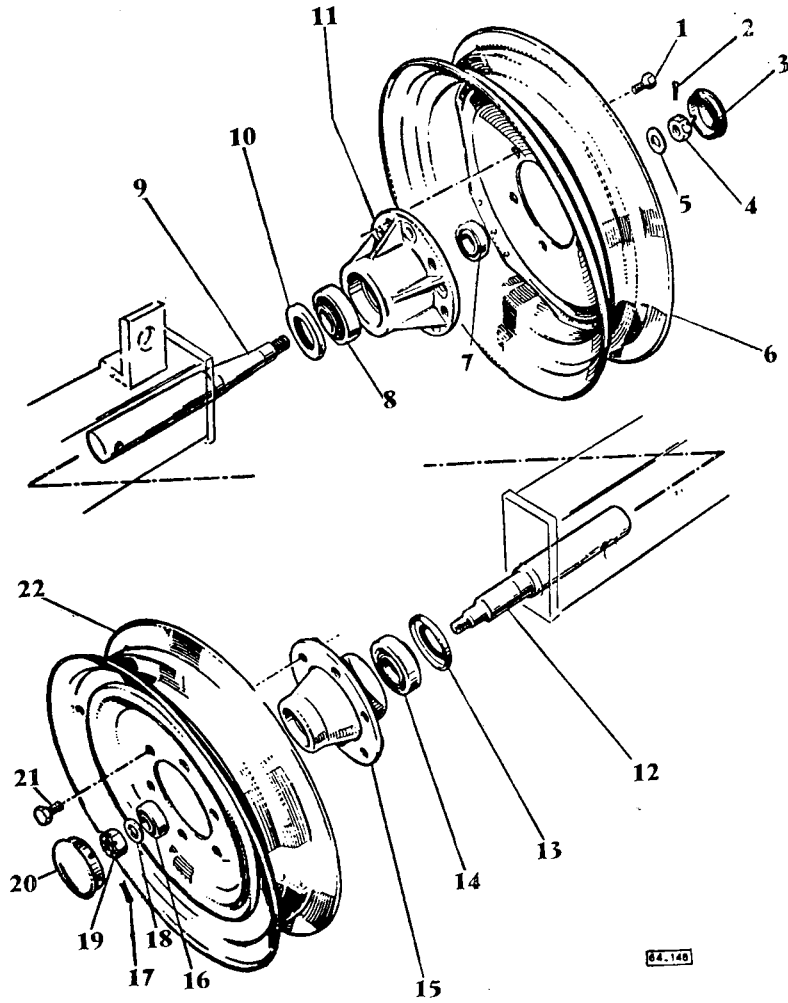

Fig. 29

BUTÉE DE PISTON (BRAS DOUBLE)  
PLUNGER STOP (DUAL ARM)  
→ N° 6448 (15-8)  
63312 (20-8)

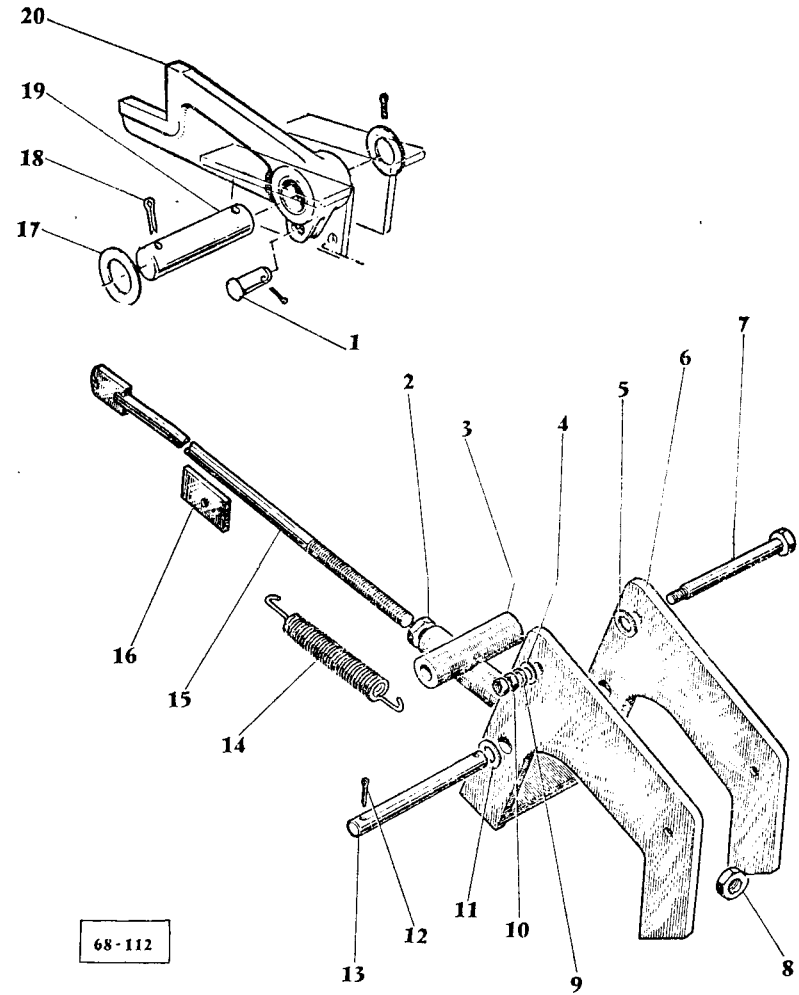

Fig. 30

BUTÉE DE PISTON  
 PLUNGER STOP  
 N° 6449 (15) 63313 (20)

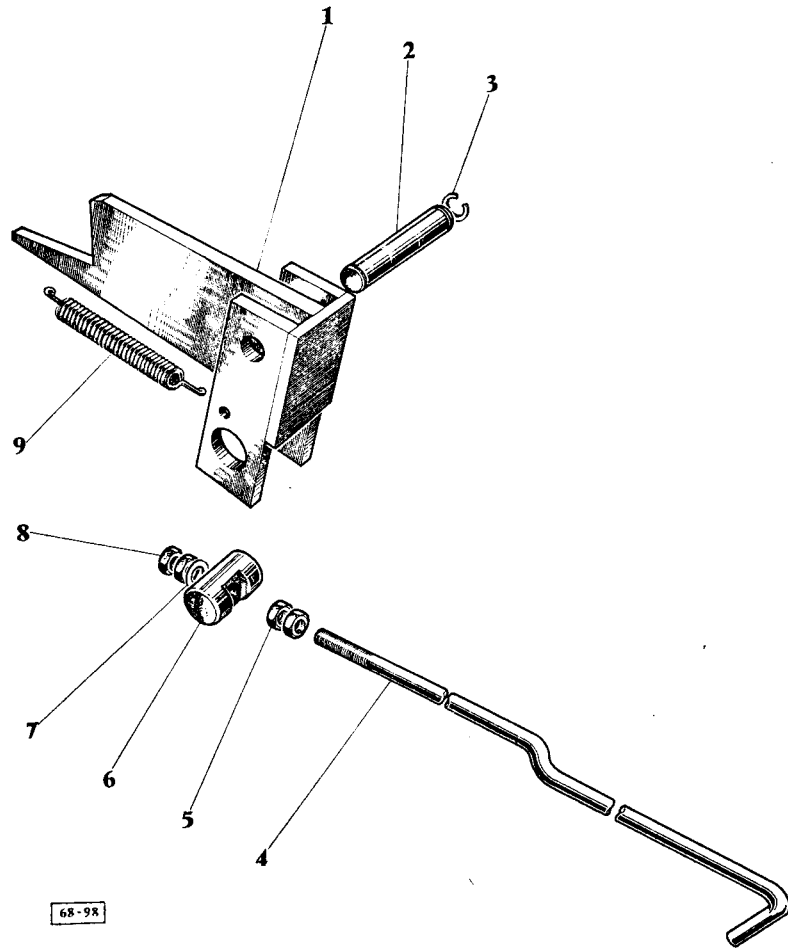

Fig. 31

ARBRE DE NOUEURS - EMBRAYAGE - DOIGTS  
 KNOTTER SHAFT - CLUTCH AND TWINE - FINGER

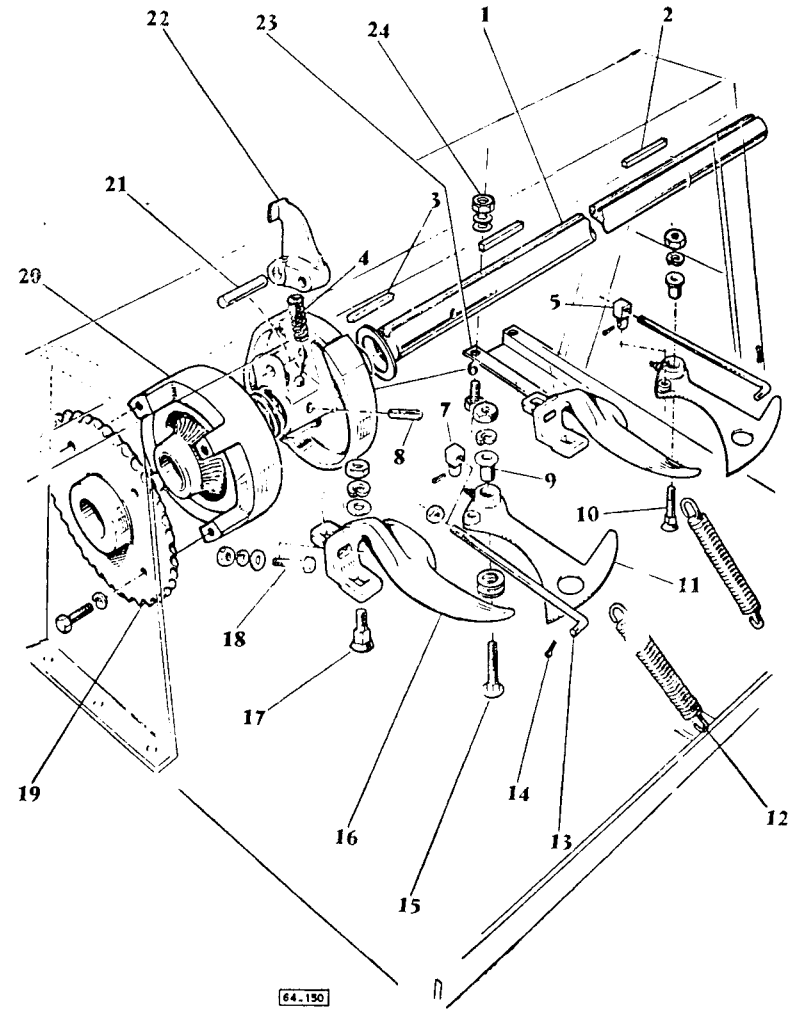

Fig. 32

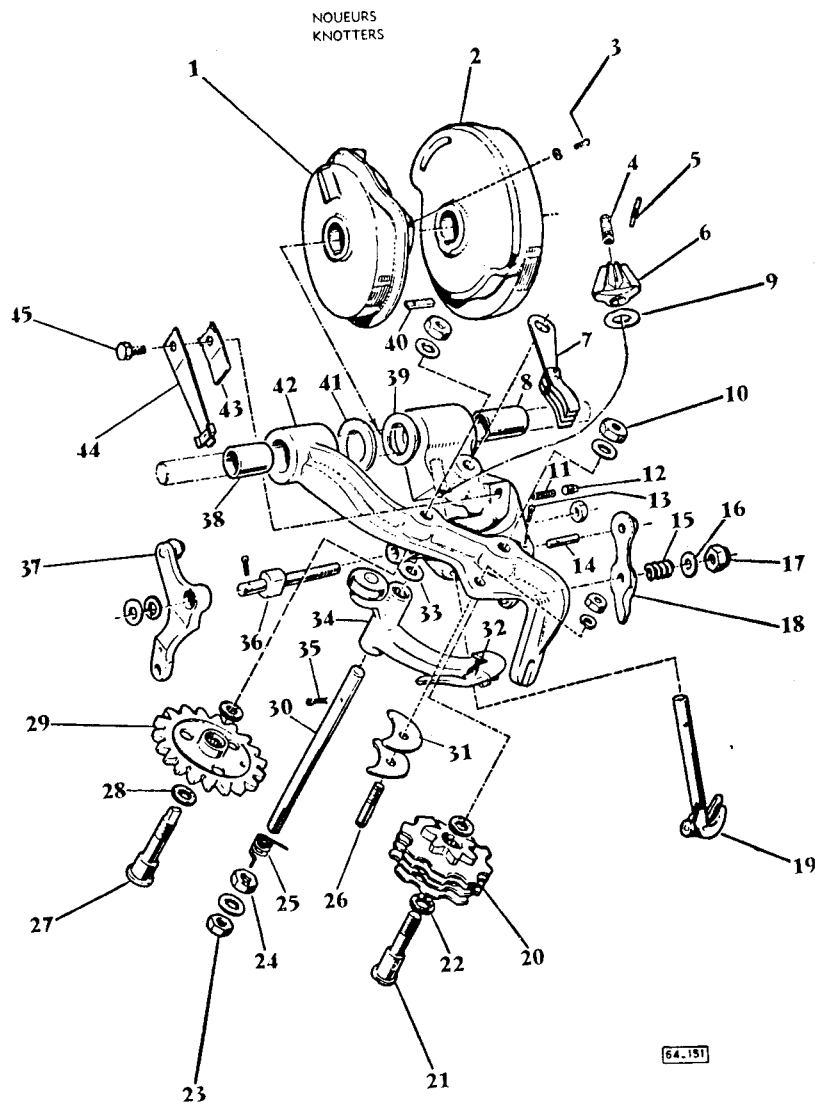

Fig. 33

FREINS DE NOUEURS - SUPPORT COMPTEUR DE BALLES  
KNOTTER-BRAKE - SUPPORT AND BALE-COUNTER

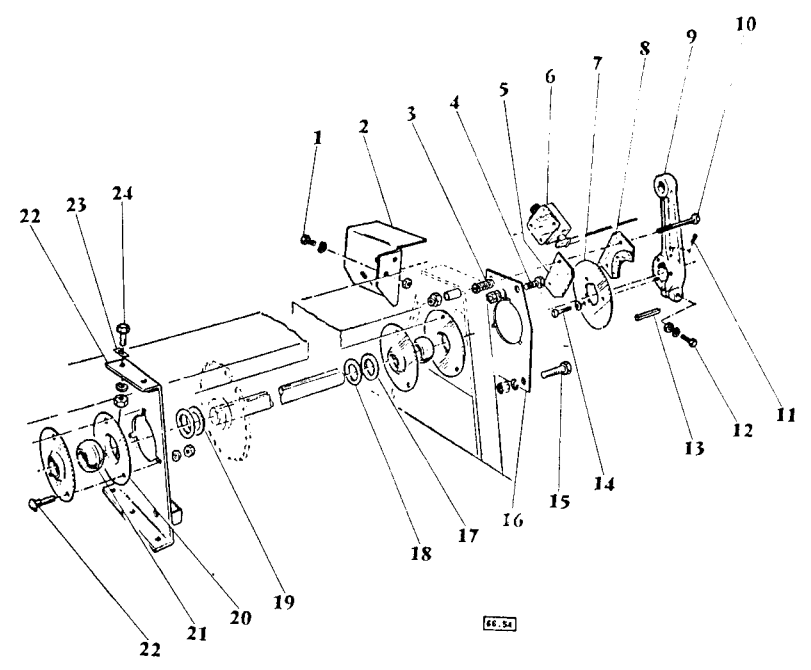
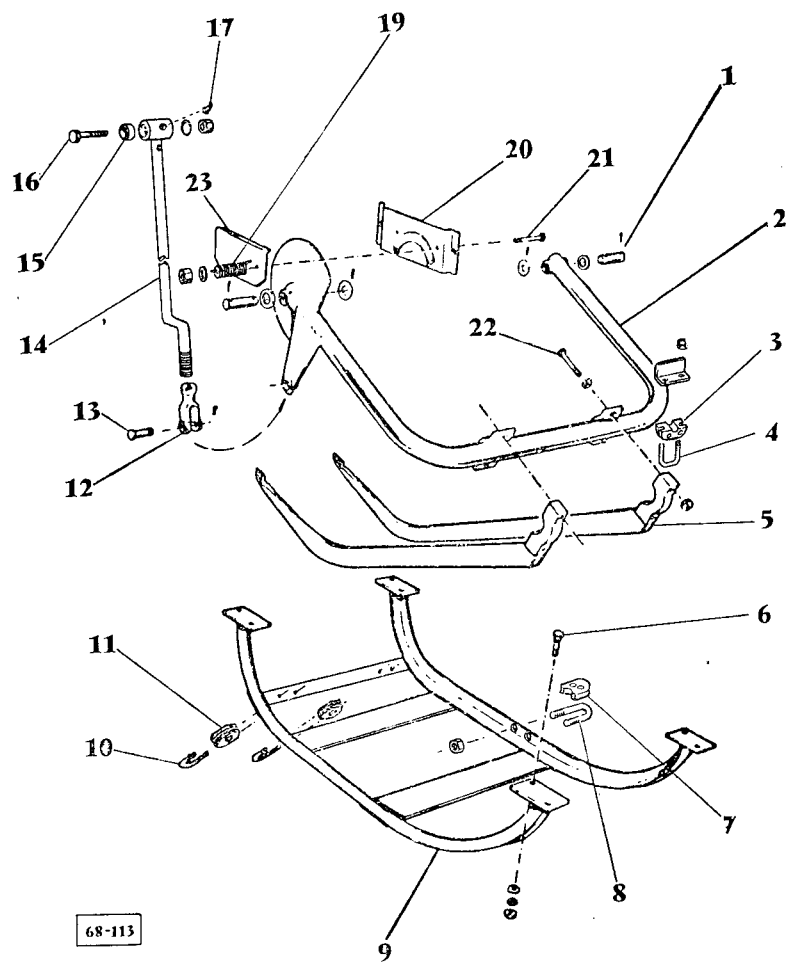

Fig. 34

AIGUILLE - FICELLE  
NEEDLE ARRANGEMENT - TWINE



68-113

Fig. 35

ROUE DE COMMANDE DU DÉCLENCHEUR  
BALE-METERING-WHEEL

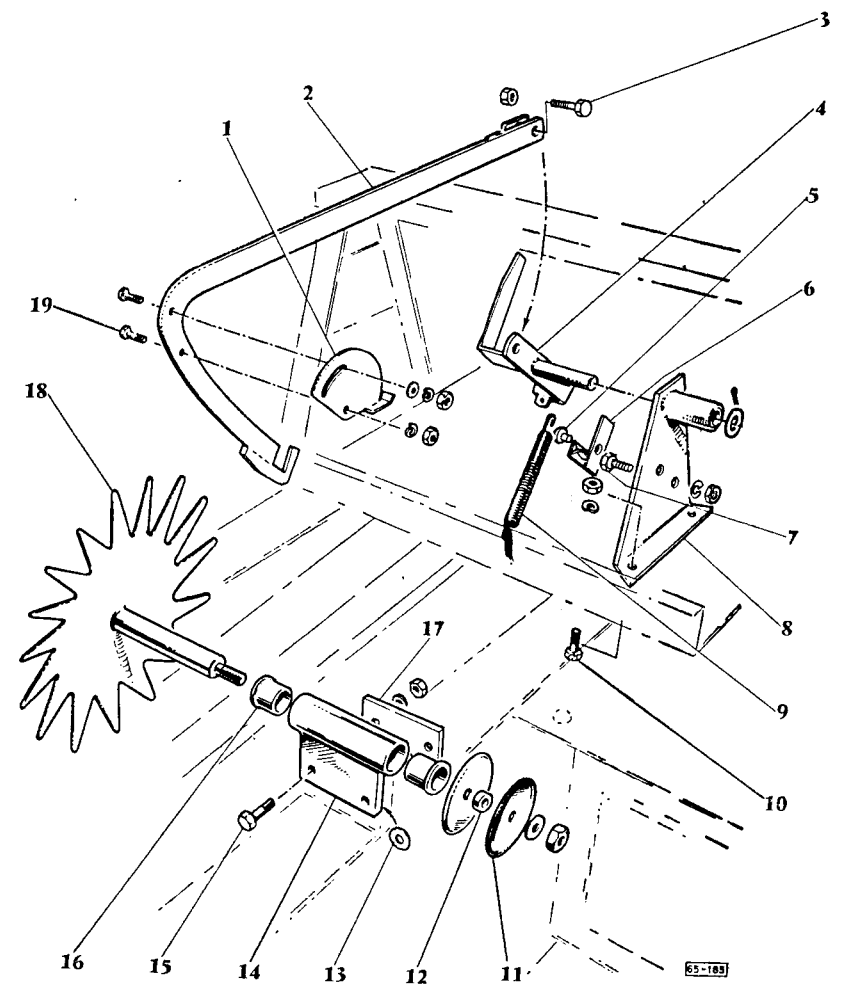

65-185

Fig. 36

RÉGLAGE DE DENSITÉ  
BALE-TENSIONNER

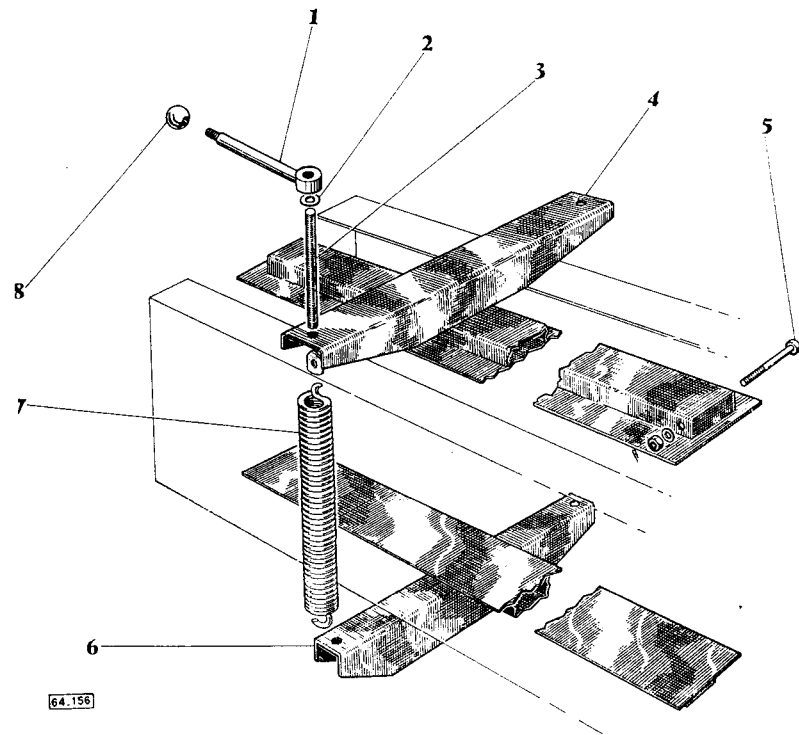

Fig. 37

RAMPE ÉLEVATRICE ET ATTELAGE REMORQUE  
BALE LOADER AND TRAILER HITCH

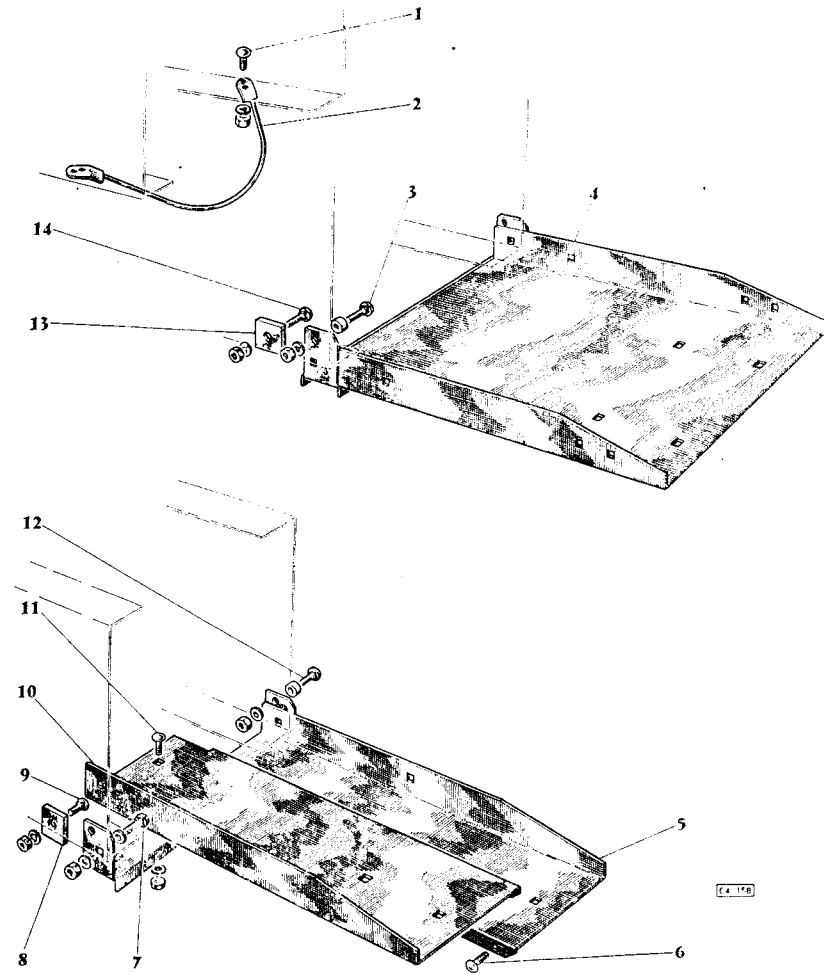

Fig. 38



RAMPE ÉLEVATRICE ET ATTELAGE REMORQUE  
BALE LOADER AND TRAILER HITCH

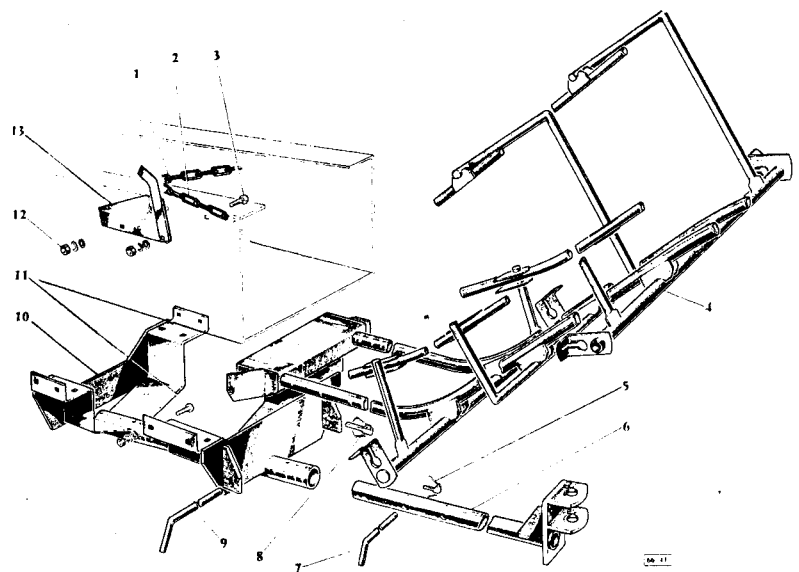

Fig. 39

RAMPE DE CHARGEMENT ET ATTELAGE REMORQUE  
BALE LOADER AND TRAILER HITCH

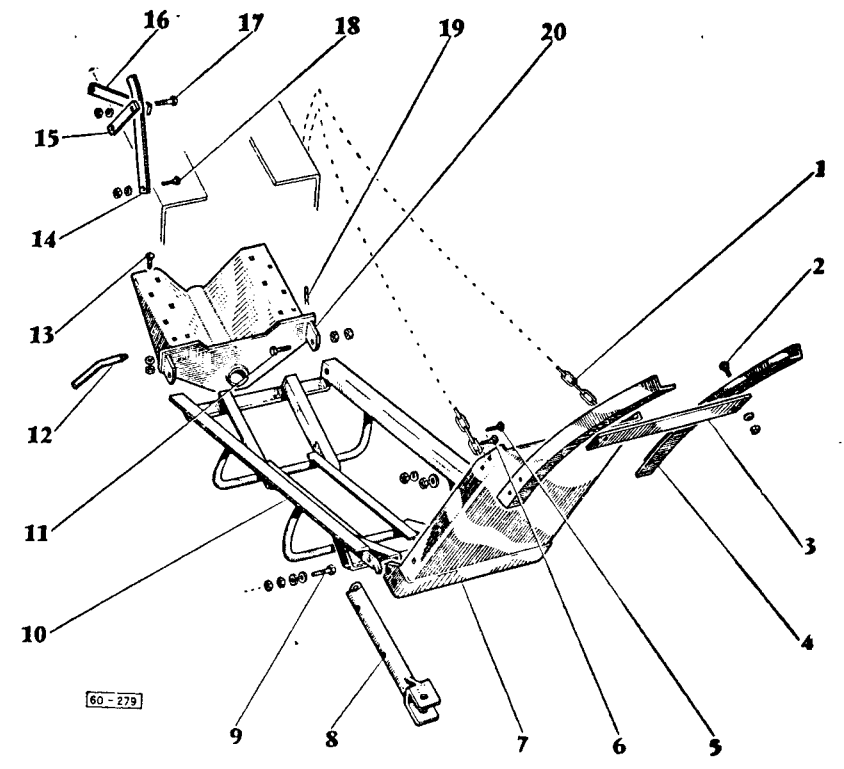

Fig. 40

COMMANDE DE CHAÎNE  
CHAIN DRIVE

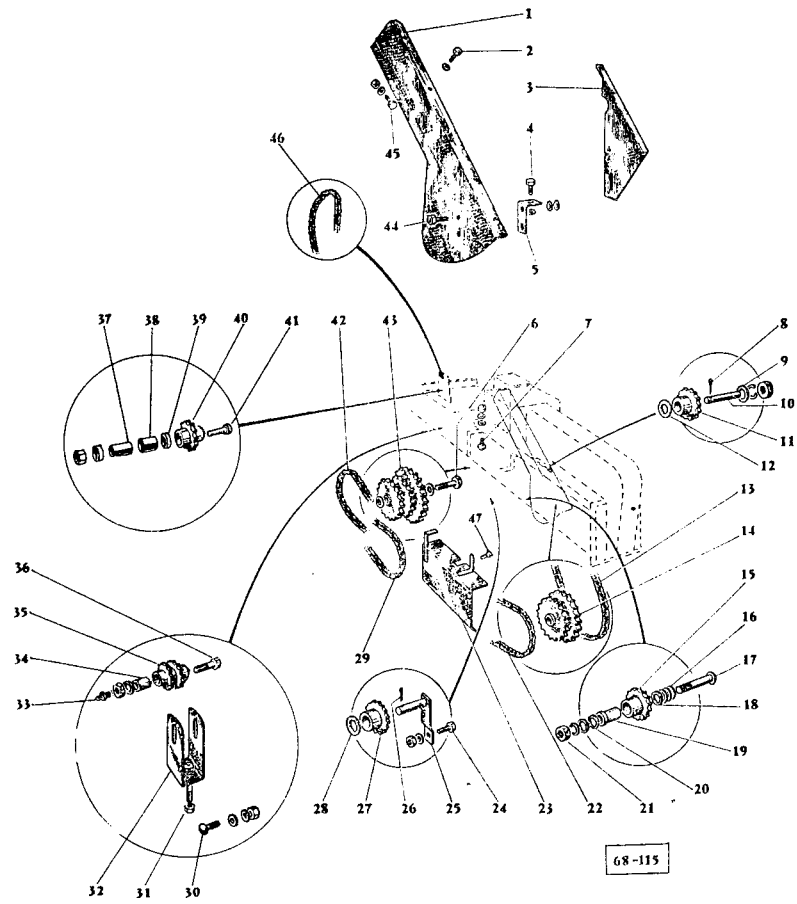

Fig. 41

ÉCLAIRAGE  
LIGHTING EQUIPMENT

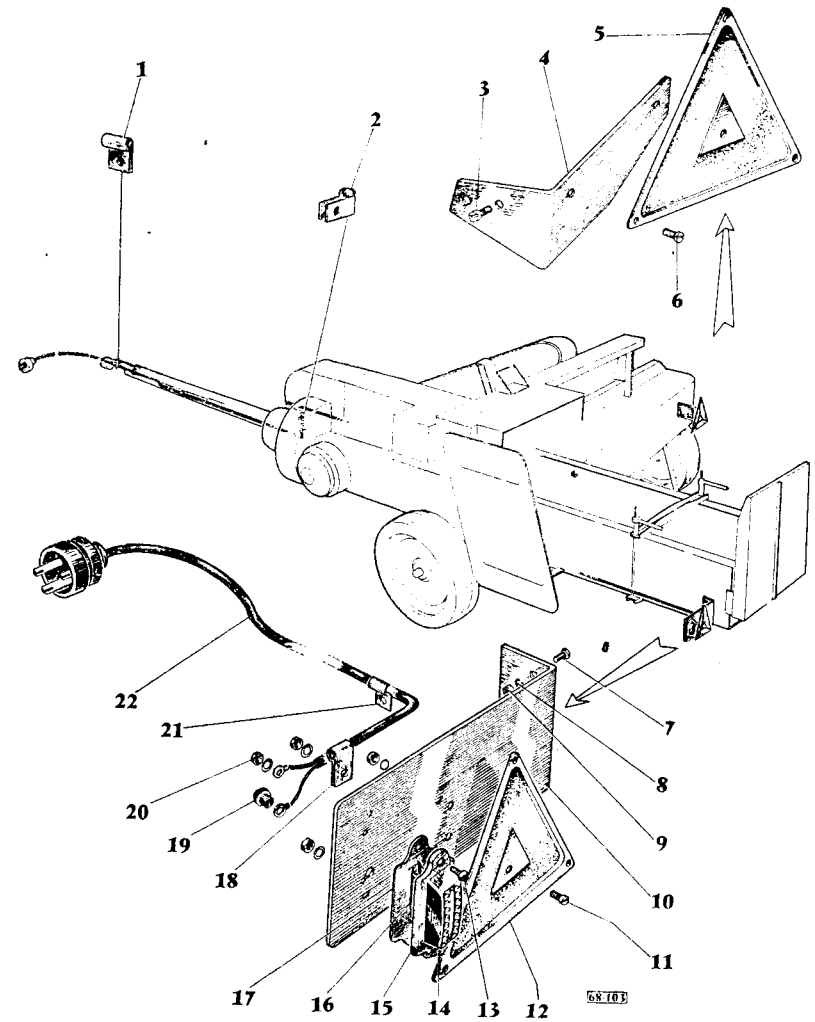

Fig. 42

CHAINES ET MAILLONS  
CHAINS AND LINKS

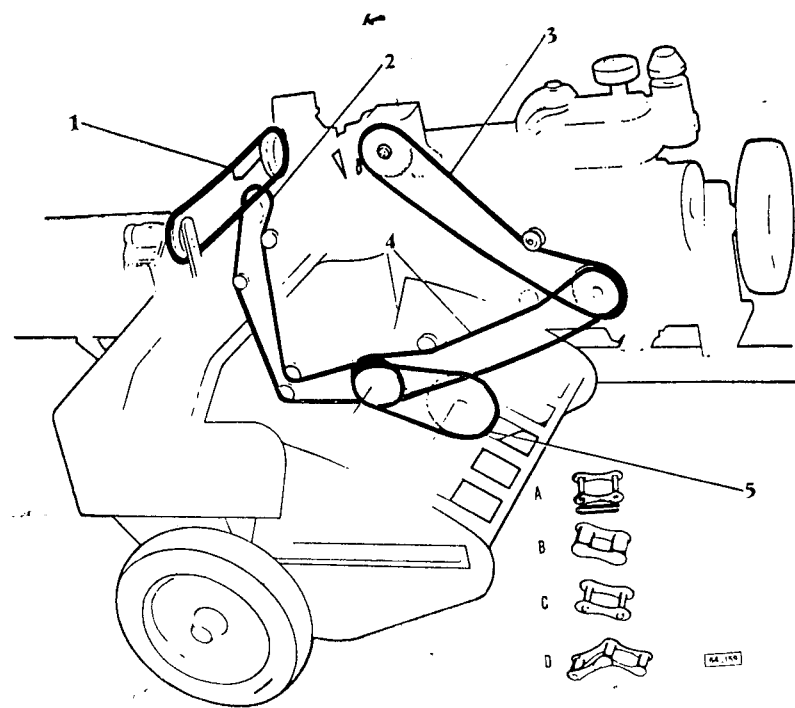

Fig. 43